

Hoval RoofVent® RG

Operating instructions

Original operating
manual

4 220 587-en-01



1 Use	3	6 Options	18
1.1 Intended use	3	6.1 Connection module	18
1.2 User group	3	6.2 Design with 2 Air-Injectors	18
2 Safety	4	6.3 Design without Air-Injector	18
2.1 Symbols	4	6.4 Paint finish of below-roof unit	18
2.2 Operational safety	4	6.5 Fresh air and exhaust air silencers	19
2.3 Decommissioning	5	6.6 Supply air and extract air silencers	20
2.4 Emergency situations	5	6.7 Condensate drain inside	20
2.5 Regulations	5	6.8 Energy monitoring	20
3 Construction and operation	6	6.9 Return temperature sensor	20
3.1 Construction	6	7 Transport and installation	21
3.2 Function diagram	8	7.1 Scope of delivery	21
3.3 Operating modes	9	7.2 Storage	22
4 Type code	12	7.3 Requirements for the installation site	23
5 Technical data	14	7.4 Installation	24
5.1 Application limits	14	7.5 Installing the air intake/flue gas system	29
5.2 Heat recovery system (HRS)	14	7.6 Connecting air ducts and Air-Injectors	30
5.3 Air filtration	14	7.7 Hydraulic installation	31
5.4 Electrical connection	14	7.8 Condensate connection	31
5.5 Air flow rate	14	7.9 Gas connection	32
5.6 Technical data of condensing gas boiler	15	7.10 Electrical installation	33
5.7 Heat output	15	8 Operation	35
5.8 Sound level	15	8.1 Initial commissioning	35
5.9 Dimensions and weights	16	8.2 Operation	35
		9 Maintenance and repair	36
		9.1 Safety	36
		9.2 Maintenance	37
		9.3 Repair	39
		10 Dismantling	39
		11 Disposal	39

1 Use

1.1 Intended use

RoofVent® RG units are supply and extract air handling units for heating spaces up to 25 m in height with decentralised condensing gas boiler. They have the following functions:

- Fresh air supply
- Extract air removal
- Heating with condensing gas boiler
- Energy recovery with highly efficient plate heat exchanger
- Filtering of the fresh air and the extract air
- Air distribution and destratification with adjustable Air-Injector

RoofVent® RG units comply with all the requirements of the Ecodesign Directive 2009/125/EC relating to environmentally friendly design of ventilation systems. They are systems of the 'non-residential ventilation unit' (NRVU) and 'bidirectional ventilation unit' (BVU) type, provided for in Commission Regulation (EU) 1253/2014.

Intended use also includes compliance with the operating instructions. Any usage over and above this use is considered to be not as intended. The manufacturer can accept no liability for damage resulting from improper use.

1.2 User group

The units are only allowed to be installed, operated and maintained by authorised and instructed personnel who are well acquainted with the units and are informed about possible dangers.

The operating instructions are for operating engineers as well as specialists in building, heating and ventilation technology.

2 Safety

2.1 Symbols

**Caution**

This symbol warns against risk of injury. Please heed all instructions designated by this symbol to prevent injuries and/or death.

**Attention**

This symbol warns against property damage. Please heed the respective instructions to prevent risk of damage to the unit and its functions.

**Notice**

This symbol denotes information about the economic use of the equipment or special tips.

2.2 Operational safety

RoofVent® units are state-of-the-art design and are safe to operate. All control and safety valves are checked at the factory. Nevertheless, hazards may emanate from the units if they are used incorrectly or not used as intended. Therefore:

- The unit may only be installed, operated and serviced by authorised, trained and instructed skilled personnel:
 - Specialists as defined by these operating instructions are those persons who, based on their training, knowledge and experience as well as their knowledge of the relevant regulations and guidelines, can carry out the work assigned to them and recognise potential hazards.
- Please read the operating instructions before unpacking, installing, commissioning and before maintaining the equipment.
- Store the operating instructions so that they are easily accessible.
- Observe any attached information and warning signs.
- Immediately replace damaged or removed informational and warning signs.
- Follow the local safety and accident prevention regulations at all times.
- Observe the particular dangers involved in working on the roof and on electrical systems.
- When working on the unit, objects (e.g. tools) could be dropped. Block off the area underneath the unit.
- Do not attach additional loads to the unit.
- When working in the unit, take precautions against unprotected, sharp metal edges.
- Wear suitable protective equipment (helmet, gloves, mouth protection, goggles).
- Following maintenance work, professionally reassemble all dismantled protective devices.
- Ensure that all access doors are properly closed to prevent water entry through the roof unit.
- Replacement parts must comply with the technical requirements of the system manufacturer. Hoval recommends the use of original spare parts.
- Unauthorised reconfiguration or modification of the unit is not permitted.
- Shut down the unit immediately, if any defects are ascertained that limit the operational safety.

2.3 Decommissioning

- Switch off heating operation (operating mode 'L_OFF').
- Close the cut-off valve in the gas supply line.
- Let the unit cool off. The heating pump continues to run to cool down the heat exchanger.

**Attention**

Fire hazard due to hot components. Do not switch off the power supply until the heating pump comes to a complete stop!

- When the heating pump comes to a stop: Turn the isolation switch on the unit to the 'Off' position.

2.4 Emergency situations

In emergency situations:

- Disconnect the power supply with the main switch in the control panel. The unit stops immediately. In this case, the orderly cool down of the heat exchanger does not happen.
- Close the cut-off valve in the gas supply line.

2.5 Regulations

Observe all applicable national regulations and standards as well as generally accepted engineering practice for the installation and operation of gas-fired units.

3 Construction and operation

3.1 Construction

The RoofVent® RG unit consists of the following components:

- Roof unit with energy recovery
- Gas boiler attachment
- Below-roof unit

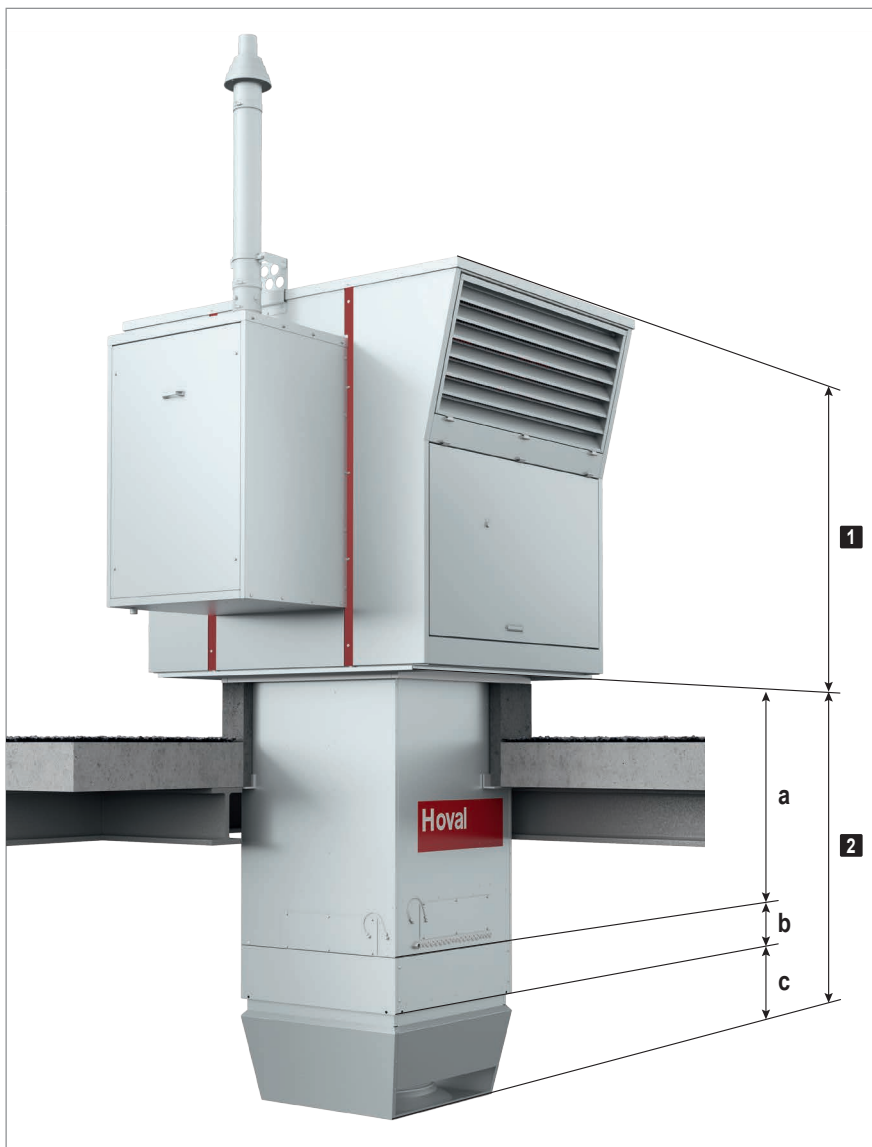

- | | |
|----------|--|
| 1 | Roof unit with energy recovery and gas boiler attachment |
| 2 | Below-roof unit |
| a | Connection module |
| b | Heating section |
| c | Air-Injector |

Fig. 1: RoofVent® RG components

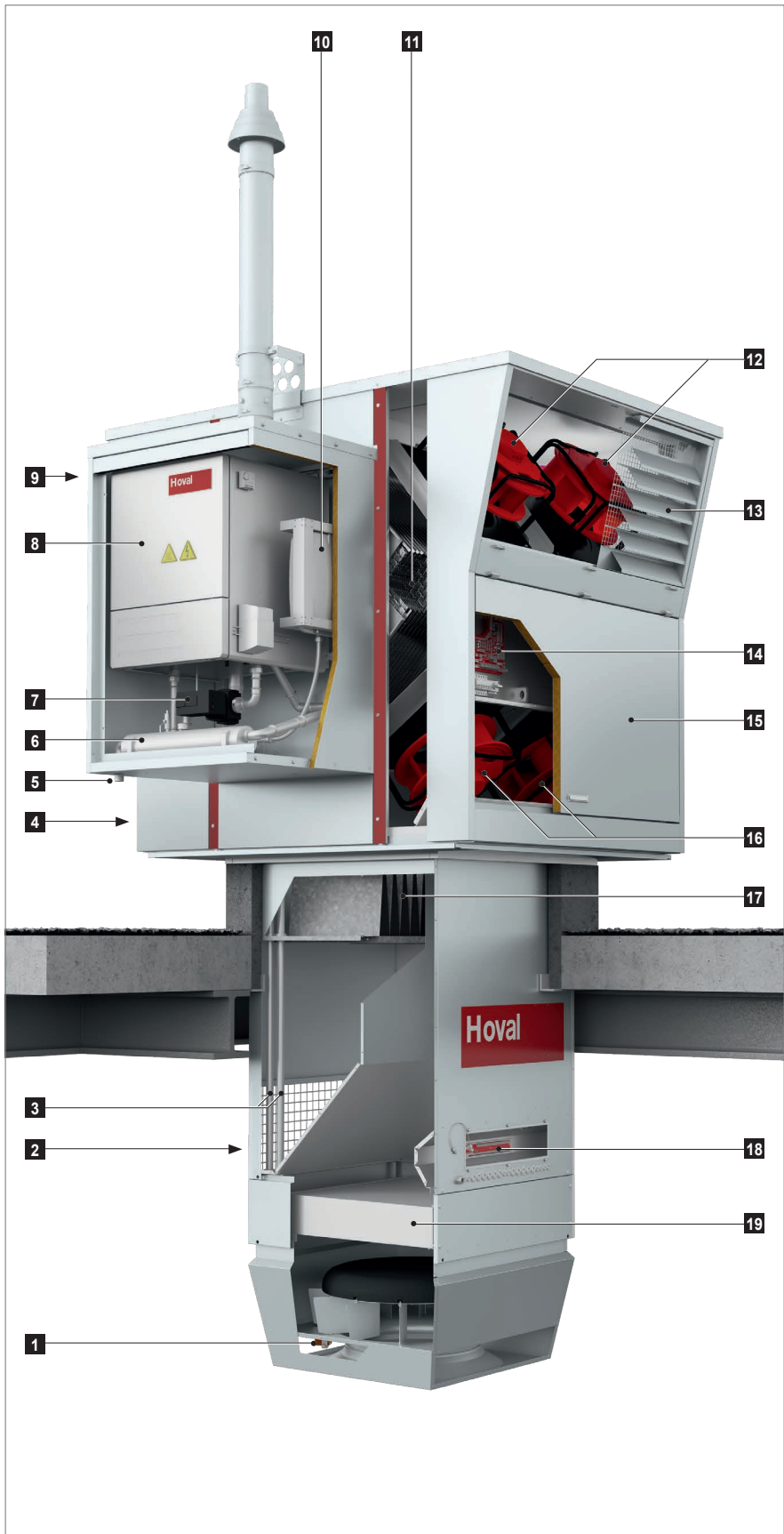

- 1** Actuator Air-Injector
- 2** Extract air grille
- 3** Flow and return pipes
- 4** Extract air access door
- 5** Condensate drain gas boiler
- 6** Neutraliser
- 7** Heating pump
- 8** Condensing gas boiler
- 9** Fresh air access door (access to the fresh air filter)
- 10** Diaphragm expansion vessel
- 11** Plate heat exchanger with bypass (for performance control and as recirculation bypass)
- 12** Exhaust air fans
- 13** Exhaust air access door
- 14** Control block
- 15** Supply air access door
- 16** Supply air fans
- 17** Extract air filter
- 18** Connection box
- 19** Heating coil

Fig. 2: RoofVent® RG construction

3.2 Function diagram

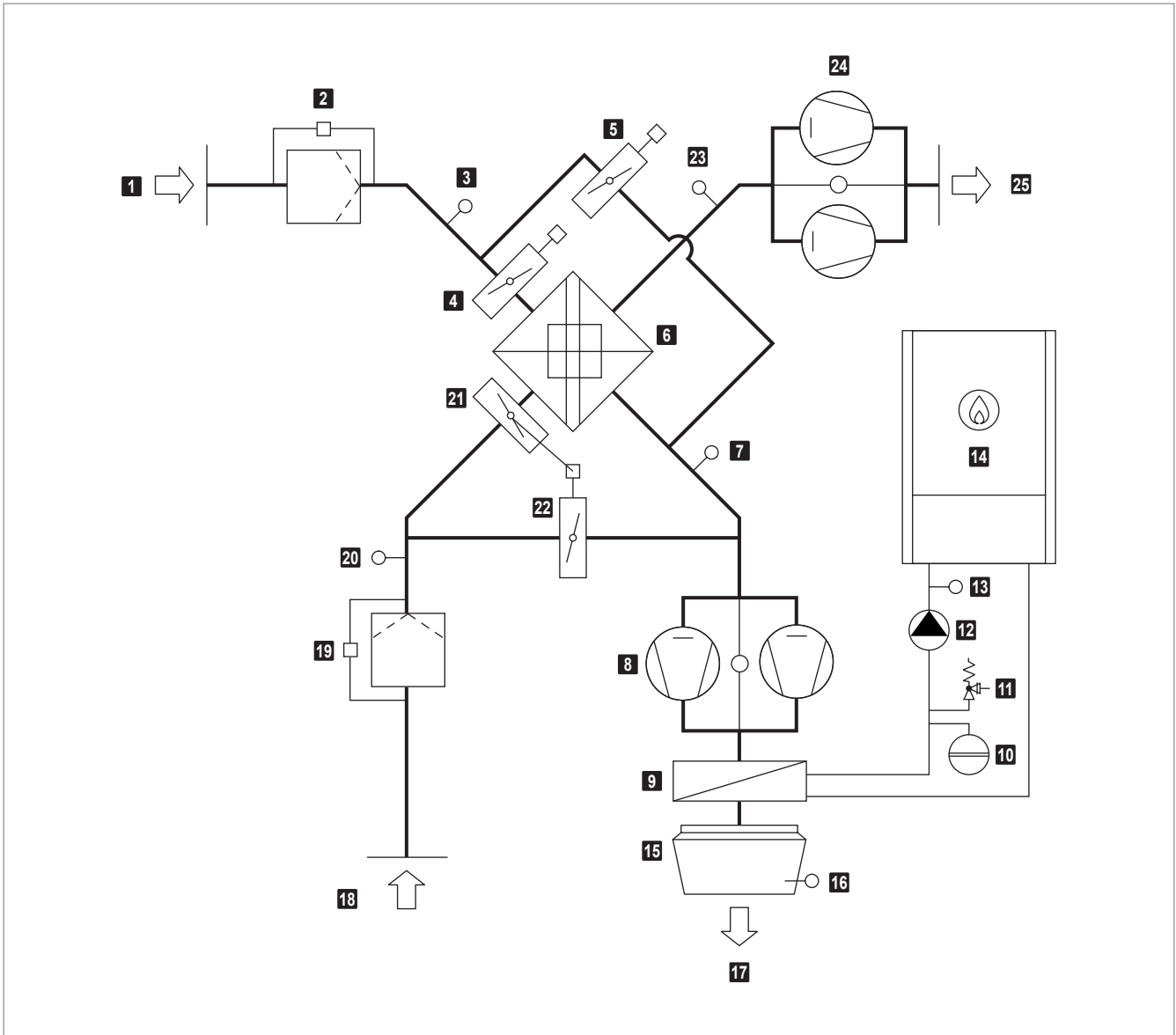

- | | |
|---|--|
| 1 Fresh air | 14 Condensing gas boiler |
| 2 Fresh air filter with differential pressure switch | 15 Air-Injector with actuator |
| 3 Temperature sensor air inlet ER (optional) | 16 Supply air temperature sensor |
| 4 Fresh air damper with actuator | 17 Supply air |
| 5 Bypass damper with actuator | 18 Extract air |
| 6 Plate heat exchanger | 19 Extract air filter with differential pressure switch |
| 7 Temperature sensor air outlet ER (optional) | 20 Extract air temperature sensor |
| 8 Supply air fans with flow rate monitoring | 21 Extract air damper with actuator |
| 9 Heating coil | 22 Recirculation damper (opposed to the extract air damper) |
| 10 Diaphragm expansion vessel | 23 Exhaust air temperature sensor |
| 11 Safety valve | 24 Exhaust air fans with flow rate monitoring |
| 12 Heating pump | 25 Exhaust air |
| 13 Return temperature sensor | |

Fig. 3: RoofVent® RG function diagram

3.3 Operating modes

The RoofVent® RG has the following operating modes:

- Ventilation
- Ventilation (reduced)
- Air quality
- Recirculation
- Exhaust air
- Supply air
- Standby

The TopTronic® C control system regulates these operating modes automatically for each control zone in accordance with the specifications in the calendar. The following points also apply:

- The operating mode of a control zone can be switched over manually.
- Each RoofVent® unit can operate individually in a local operating mode: Off, Recirculation, Supply air, Exhaust air, Ventilation.

Code	Operating mode		Description
VE	<p>Ventilation</p> <p>The unit blows fresh air into the room and exhausts polluted room air. The room temperature set value day is active. Depending on the temperature conditions, the system continuously controls:</p> <ul style="list-style-type: none"> ■ the energy recovery ■ the heating 		<p>Supply air fan on ¹⁾</p> <p>Exhaust air fan on ¹⁾</p> <p>Energy recovery 0-100 %</p> <p>Extract air damper open</p> <p>Recirculation damper closed</p> <p>Heating 0-100 %</p> <p>¹⁾ Adjustable flow rate</p>
VEL	<p>Ventilation (reduced)</p> <p>As VE, but the unit only operates with the set minimum values for the supply and exhaust air volumes</p>		<p>Supply air fan MIN</p> <p>Exhaust air fan MIN</p> <p>Energy recovery 0-100 %</p> <p>Extract air damper open</p> <p>Recirculation damper closed</p> <p>Heating 0-100 %</p>
AQ	<p>Air quality</p> <p>This is the operating mode for demand-controlled ventilation of the room. The room temperature set value day is active. Depending on the temperature conditions, the system continuously controls:</p> <ul style="list-style-type: none"> ■ the energy recovery ■ the heating <p>Depending on the room air quality or room air humidity, the system operates in one of the following operating states:</p>		
AQ_REC	<ul style="list-style-type: none"> ■ Air quality Recirculation: When air quality is good and air humidity appropriate, the unit heats in recirculation operation. 		Like REC
AQ_ECO	<ul style="list-style-type: none"> ■ Air quality Mixed air: When ventilation requirements are medium, the unit heats in mixed air operation. The supply and exhaust air volume is based on the air quality. 		<p>Supply air fan MIN-MAX</p> <p>Exhaust air fan MIN-MAX</p> <p>Energy recovery 0-100 %</p> <p>Extract air damper 50 %</p> <p>Recirculation damper 50 %</p> <p>Heating 0-100 %</p>

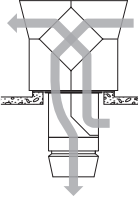
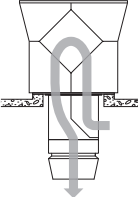
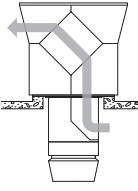
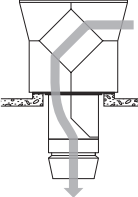
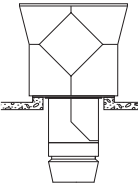
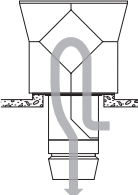
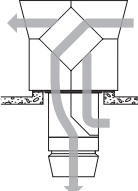
AQ_VE	<ul style="list-style-type: none"> ■ Air quality Ventilation: When ventilation requirements are high or the room air humidity is too high, the unit heats in pure ventilation operation. The supply and exhaust air volume is based on the air quality. 		Supply air fan MIN-MAX Exhaust air fan MIN-MAX Energy recovery 0-100 % Extract air damper open Recirculation damper closed Heating 0-100 %
REC DES	<p>Recirculation On/Off recirculation operation with TempTronic algorithm: during heat demand, the unit draws in room air, heats it and blows it back into the room. The room temperature set value day is active. The flow rate is controlled in 2 stages.</p> <ul style="list-style-type: none"> ■ Destratification: To avoid heat build-up under the ceiling, it may be appropriate to switch on the fan when there is no heat demand (either in permanent operation or in on/off operation depending on the temperature stratification, as desired). 		Supply air fan 0 / MIN / MAX ¹⁾ Exhaust air fan off Energy recovery 0 % Extract air damper closed Recirculation damper open Heating on ¹⁾ 1) Depending on heat demand
EA	<p>Exhaust air The unit extracts spent room air. There is no room temperature control. Unfiltered fresh air enters the room through open windows and doors or another system provides air supply.</p>		Supply air fan off Exhaust air fan on ¹⁾ Energy recovery 0 % Extract air damper open Recirculation damper closed Heating off 1) Adjustable flow rate
SA	<p>Supply air The unit blows fresh air into the room. The room temperature set value day is active. Depending on the temperature conditions, the system controls the heating. Spent room air passes through open windows and doors or another system provides extraction.</p>		Supply air fan on ¹⁾ Exhaust air fan off Energy recovery 0 % ²⁾ Extract air damper open Recirculation damper closed Heating 0-100 % 1) Adjustable flow rate 2) Fresh air and bypass dampers are open
ST	<p>Standby The unit is ready for operation. The following operating modes are activated if required:</p>		
CPR	<ul style="list-style-type: none"> ■ Cooling protection: If the room temperature drops below the set value for cooling protection, the unit heats up the room in recirculation operation. 		Supply air fan MAX Exhaust air fan off Energy recovery 0 % Extract air damper closed Recirculation damper open Heating on
NCS	<ul style="list-style-type: none"> ■ Night cooling: If the room temperature exceeds the set value for night cooling and the current fresh air temperature permits it, the unit blows cool fresh air into the room and extracts warmer room air. 		Supply air fan on ¹⁾ Exhaust air fan on ¹⁾ Energy recovery 0 % Extract air damper open Recirculation damper closed Heating off 1) Adjustable flow rate

<p>L_OFF</p>	<p>Off (local operating mode) The unit is switched off.</p>		<p>Supply air fan off Exhaust air fan off Energy recovery 0 % Extract air damper closed Recirculation damper open Heating off</p>
<p>–</p>	<p>Forced heating The unit draws in room air, warms it and blows it back into the room. For example, forced heating is suitable for heating the hall before taking the control system into operation or if the controller fails during the heating period. Connecting a room thermostat makes it possible to specify a room temperature set value. Forced heating can be activated and set as required by the Hoval service technician.</p>		<p>Supply air fan MAX Exhaust air fan off Energy recovery 0 % Extract air damper closed Recirculation damper open Heating on</p>

Table 1: RoofVent® RG operating modes

4 Type code

RG - 9 Z - -RY / ST . -- / V0 . D1 . LU / AF . SI / - . -- . CI . -- / TC . EM . -- . RF

Unit type

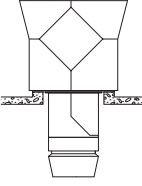
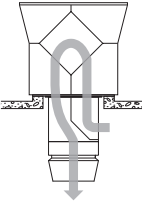
RoofVent® RG

Unit size

9

Heating section

Z with coil type Z

Heat recovery

RY Temperature efficiency ErP 2018

Design

ST Standard

Connection module

- V0 Standard
- V1 Length + 250 mm
- V2 Length + 500 mm
- V3 Length + 1000 mm

Air outlet

- D1 Design with 1 Air-Injector
- D2 Design with 2 Air-Injectors
- D0 Design without Air-Injector

Paint finish

- without
- LU Paint finish of below-roof unit

Silencers outside

- without
- AF Fresh air and exhaust air silencers

Silencers inside

- without
- SI Supply air and extract air silencers

Condensate drain of condensing gas boiler

- Standard (onto the roof)
- CI Condensate drain inside

RG - 9 Z - -RY / ST . -- / V0 . D1 . LU / AF . SI / - CI . -- / TC . EM . -- . RF

Control system

TC TopTronic® C

Energy monitoring

-- without

EM Energy monitoring

Return temperature sensor

RF Return temperature sensor

Table 2: Type code

5 Technical data

5.1 Application limits

Fresh air temperature	min.	°C	- 15
Extract air temperature	max.	°C	50
Moisture content of extract air ¹⁾	max.	g/kg	15
Supply air temperature	max.	°C	60
Temperature of the heating medium	max.	°C	85
Pressure of the heating medium	min.	kPa	200
	max.	kPa	300
Air flow rate	min.	m ³ /h	5000

1) Moisture increase in the room max. 2 g/kg

Table 3: Application limits

5.2 Heat recovery system (HRS)

Temperature efficiency, dry	%	74
Temperature efficiency, wet	%	84

Table 4: Thermal transfer level of the plate heat exchanger

5.3 Air filtration

Filter	Fresh air	Extract air
Class acc. to ISO 16890	ePM ₁ 55 %	ePM ₁₀ 60 %
Class acc. to EN 779	F7	M6
Factory setting of differential pressure switches	250 Pa	300 Pa

Table 5: Air filtration

5.4 Electrical connection

Supply voltage	V AC	3 × 400
Permitted voltage tolerance	%	± 5
Frequency	Hz	50
Connected load	kW	8.31
Current consumption max.	A	14.2
Series fuse	A	20.0

Table 6: RoofVent® RG electrical connections

5.5 Air flow rate

Nominal air flow rate	m ³ /h	8000
Floor area covered	m ²	797

Table 7: Air flow rate

5.6 Technical data of condensing gas boiler

Rated heating capacity at 80/60 °C	kW	13.4 – 71.8
Rated heating capacity at 50/30 °C	kW	14.8 – 79.1
Nominal heat input ¹⁾	kW	13.8 – 75.8
Water-side operating pressure		
min.	kPa	100
max. (PMS)	kPa	400
Test pressure (PT)	kPa	600
Boiler water volume (V _(H2O))	l	5.4
Minimum circulation water volume	l/h	550
Boiler efficiency		
at 80/60 °C in full-load operation H _i /H _s		96.3/86.8
at 30% partial load operation H _i /H _s		107.8/97.3
NO _x class (EN 15502)	–	6
Nitrous oxide emission (EN 15502) (H _s)	mg/kWh	29.0
CO ₂ content in the flue gas min. / max. output	%	8.8/8.8
Gas flow pressure min. / max.	mbar	17.4 – 50
Gas connection values at 15 °C / 1013 mbar		
Natural gas E (Wo = 15.0 kWh/m ³) H = 9.97 kWh/m ³	m ³ /h	1.4 – 7.6
Natural gas LL (Wo = 12.4 kWh/m ³) H = 8.57 kWh/m ³	m ³ /h	1.6 – 8.8
Condensate quantity at 50/30 °C	l/h	7.1

1) Data relates to Hi. The boiler series is tested for EE/H setting. With a factory setting of a Wobbe number of 15.0 kWh/m³, operation in the Wobbe number range of 12.0 to 15.7 kWh/m³ is possible without readjustment.

Table 8: Technical data TopGas® classic (80)

5.7 Heat output

Fresh air temp.	– 5 °C				– 15 °C			
	Q	Q _{TG}	H _{max}	t _s	Q	Q _{TG}	H _{max}	t _s
Unit type	kW	kW	m	°C	kW	kW	m	°C
RG-9	70	57.9	11.9	39.5	70	51.8	12.5	37.2

Legend: Q = Coil heat output
Q_{TG} = Output to cover fabric heat losses
H_{max} = Maximum mounting height
t_s = Supply air temperature

Reference: Room air: 18 °C
Extract air: 20 °C / 20 % rel. humidity
Heat transfer fluid: 34 % glycol (Protect Glycol E from Tevier)

Table 9: RoofVent® RG heat output

5.8 Sound level

Casing sound power level	dB(A)	72
--------------------------	-------	----

Table 10: Sound level

5.9 Dimensions and weights

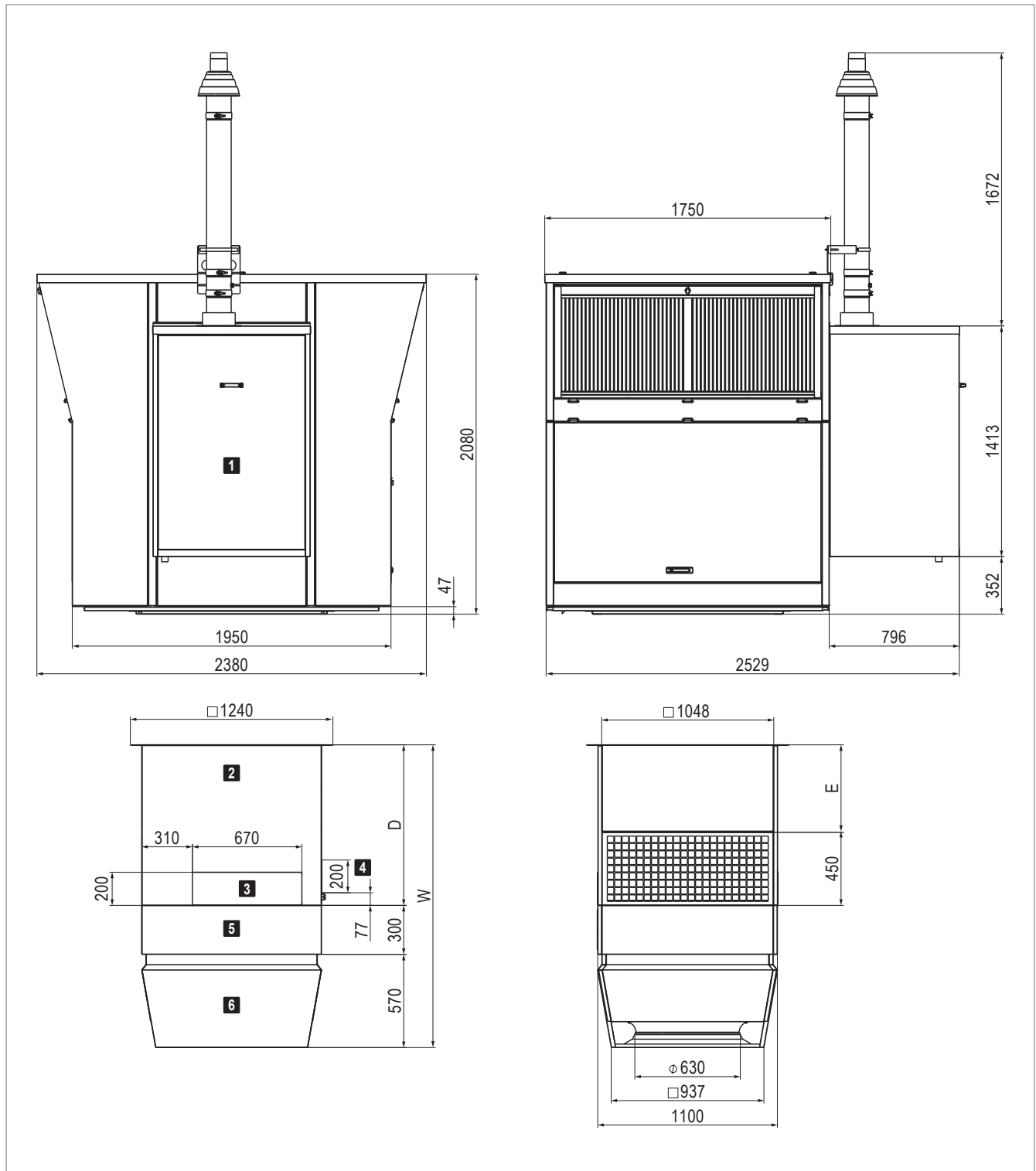

- 1** Roof unit with energy recovery and gas boiler attachment
- 2** Connection module
- 3** Access panel, coil

- 4** Access panel, connection box
- 5** Heating section
- 6** Air-Injector

Fig. 4: RoofVent® RG dimensional drawing (dimensions in mm)

Connection module		V0	V1	V2	V3
D	mm	980	1230	1480	1980
E	mm	530	780	1030	1530
W	mm	1850	2100	2350	2850

Table 11: RoofVent® RG dimensions

Unit type		RG-9
Total	kg	1251
Roof unit	kg	1050
Below-roof unit	kg	201
Air-Injector	kg	56
Heating section	kg	51
Connection module V0	kg	94
Additional weight V1	kg	+ 13
Additional weight V2	kg	+ 26
Additional weight V3	kg	+ 52

Table 12: RoofVent® RG weights

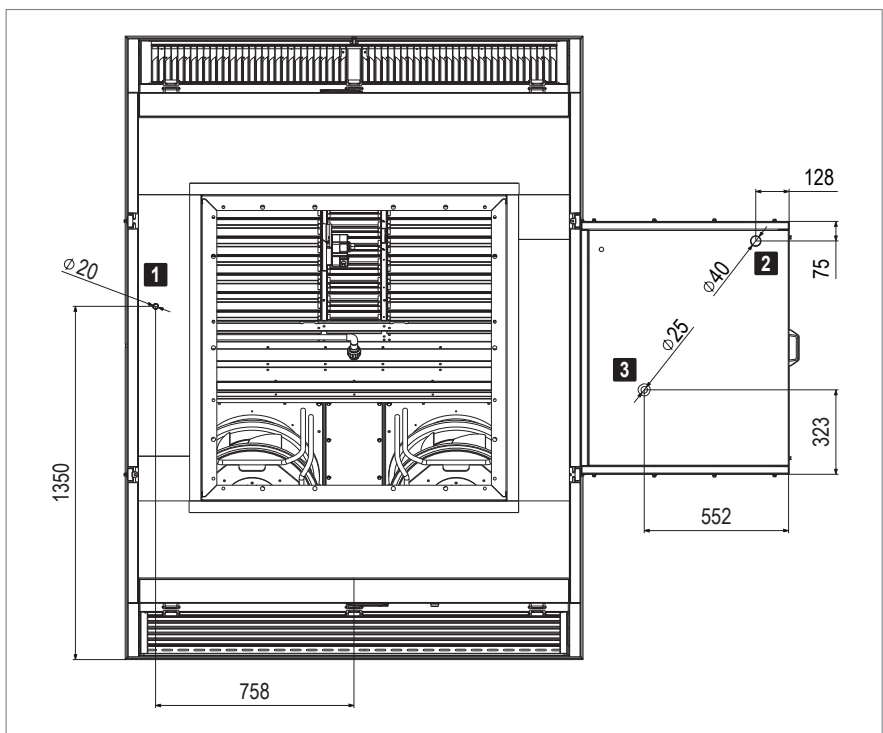

- 1 Condensate drain plate heat exchanger
- 2 Condensate drain gas boiler
- 3 Feedthrough of the gas supply line

Fig. 5: Dimension sheet for condensate drain and gas supply line (view of roof unit from below, dimensions in mm)

6 Options

6.1 Connection module

The connection module is available in 4 lengths for adapting the RoofVent® unit to local conditions.

6.2 Design with 2 Air-Injectors

A supply air duct can be connected to the RoofVent® unit for distributing the supply air over a very wide area. 2 Air-Injectors can be installed on this.

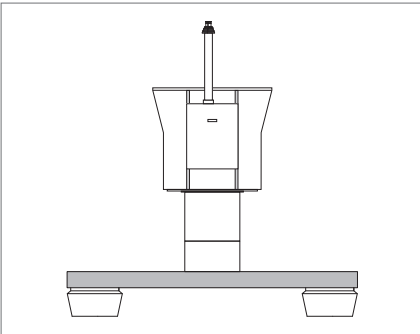

Fig. 6: RoofVent® unit with supply air duct and 2 Air-Injectors

6.3 Design without Air-Injector

RoofVent® units in the design without Air-Injector are suitable for connecting to an air distribution system supplied by the client.

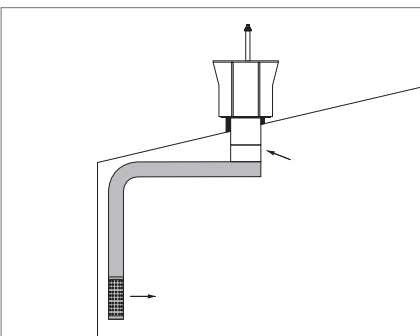

Fig. 7: Connection to an air distribution system supplied by the client

6.4 Paint finish of below-roof unit

The entire below-roof unit including optional components is painted in any colour.

6.5 Fresh air and exhaust air silencers

The fresh air silencer reduces noise emissions from RoofVent® units on the fresh air side. It consists of an aluminium casing with a bird screen and acoustic insulation lining and is configured as an add-on part for the roof unit which can be folded downwards.

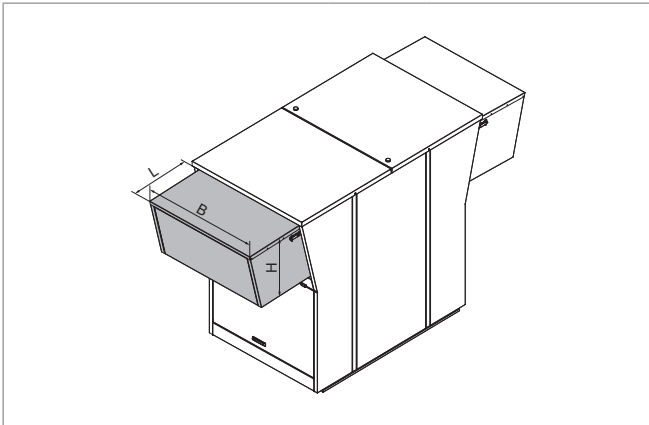

L	mm	625
B	mm	1630
H	mm	650
Weight	kg	42
Pressure drop	Pa	10

Table 13: Technical data fresh air silencer

The exhaust air silencer reduces noise emissions from RoofVent® units on the exhaust air side. It consists of an aluminium casing with a bird screen and sound attenuation splitters and is configured as an add-on part for the roof unit which can be folded downwards.

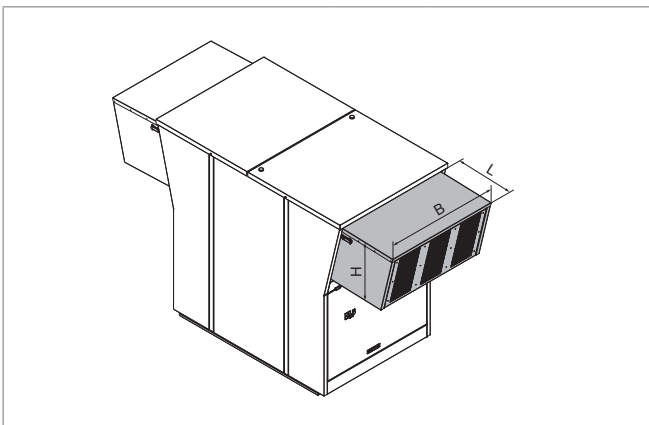

L	mm	625
B	mm	1630
H	mm	650
Weight	kg	68
Pressure drop	Pa	53

Table 14: Technical data exhaust air silencer

6.6 Supply air and extract air silencers

Supply air and extract air silencers reduce the noise from RoofVent® units within the room. The supply air silencer is designed as a separated component and is installed above the Air-Injector. The extract air silencer consists of acoustic insulation lining in the connection module.

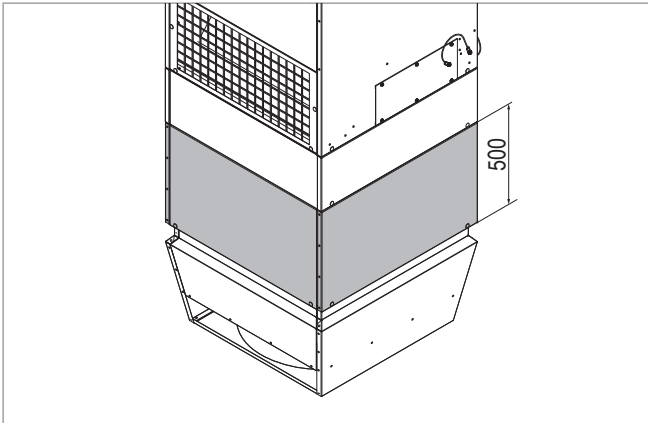

Weight	kg	80
Supply air pressure drop	Pa	26
Extract air pressure drop	Pa	0

Table 15: Technical data supply air and extract air silencers

6.7 Condensate drain inside

The neutralised condensate from the gas condensing boiler can be channelled inside the RoofVent® unit to the drain connection in the connection module. To prevent icing of the condensate, the condensate line is heated.

6.8 Energy monitoring

Energy monitoring makes it possible to display the energy saved by heat recovery. For this purpose, 2 additional temperature sensors are installed in the RoofVent® units; they record the air inlet and air outlet temperatures of the plate heat exchanger.

6.9 Return temperature sensor

The return temperature sensor monitors the return temperature of the heating medium.



Notice

RoofVent® RG units are equipped with a return temperature sensor in the gas boiler attachment as standard.

7 Transport and installation



Caution

Risk of injury from incorrect handling. Transport, assembly and installation work may only be performed by specialists. Observe safety and accident prevention regulations.

7.1 Scope of delivery

The scope of delivery includes:

- RoofVent® unit, delivered as standard in 2 parts on pallets (roof unit, below-roof unit)
- Accessories
- Optional components
- Zone control panel

Associated parts are labelled with the same unit number and serial number. Depending on the unit size, the below-roof unit can also be delivered in multiple parts.

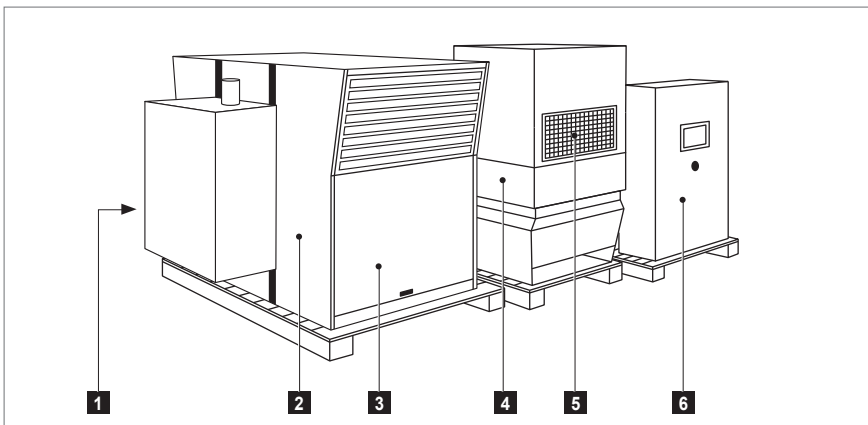

- | | |
|---|---------------------------|
| 1 | Extract air access door |
| 2 | RoofVent® roof unit |
| 3 | Supply air access door |
| 4 | RoofVent® below-roof unit |
| 5 | Extract air grille |
| 6 | Zone control panel |

Fig. 8: Delivery of the components on pallets

Accessories

The following accessories are supplied separately:

- Transport eyes for lifting the below-roof unit and the roof unit (2 each, attached to the pallet of the first roof unit)
- Screws for assembling the units and for fixing the fan protecting plate (attached to the pallet of the roof unit)
- If the below-roof unit is delivered in multiple parts: Screws for assembling the below-roof unit (behind the extract air grille)
- PG screw joint for electrical connection (behind the connection box access panel; this is located in the below-roof unit opposite the extract air grille)
- Electrical diagram and 2 keys for the access doors (behind the supply air access door)
- Fresh air temperature sensor and room air temperature sensor (in the zone control panel)
- Air intake/flue gas system with spacer and fastening bracket (behind the supply air access door)
- Metal hoses for the heating circuit (behind the supply air access door)
- Heat transfer fluid (behind the supply air access door)

Options

The following optional components are supplied separately:

- Fresh air and exhaust air silencer (on separate pallet; bolts, hinges and screws enclosed)
- Additional room temperature sensors, combination sensor room air quality, temperature and humidity (in zone control panel)
- Version with 2 Air-Injectors or without Air-Injector: A supply air temperature sensor is enclosed behind the extract air grille.



Notice

Below-roof units with a connection module of length V3 are shipped horizontally. In this case, loose parts are not placed behind the extract air grille but behind the extract air access door in the roof unit.

Preparation

- The units are delivered screwed onto the pallet. To loosen the screws, the inspection doors must be opened. When unloading the units, make sure that there is enough space to open the inspection doors.
- Use a forklift with a sufficiently long fork to unload (at least 1.8 m).
- Check the consignment against the delivery documents and the order confirmation to ensure that it is complete. Report missing parts and any damage immediately in writing.

7.2 Storage

If you do not install the unit immediately:

- Remove the packaging film to avoid water vapour condensation.
- Store the unit in a dry, dust-free room.
- Keep the storage temperature between -10°C and $+50^{\circ}\text{C}$.
- Avoid too long storage periods. After a storage period of more than 1 year:
 - Check that the bearings of the fans move smoothly before installing the unit.

7.3 Requirements for the installation site

- Make sure that the roof has sufficient load-bearing capacity and that the roof frames correspond to the specifications in the design handbook.
- Position the units according to the system layout. Pay attention to the orientation of the units to each other and observe the minimum and maximum distances. Units must not draw in exhaust air from other units as fresh air.
- All air inlet and air outlet openings must be freely accessible. The supply air jet must be free to spread out unhindered.
- The access doors in the roof unit and the access panels in the below-roof unit must be easily accessible.
- The Air-Injector must be easily accessible.
- Clearance of at least 0.9 m is required for maintenance work around the heating section.

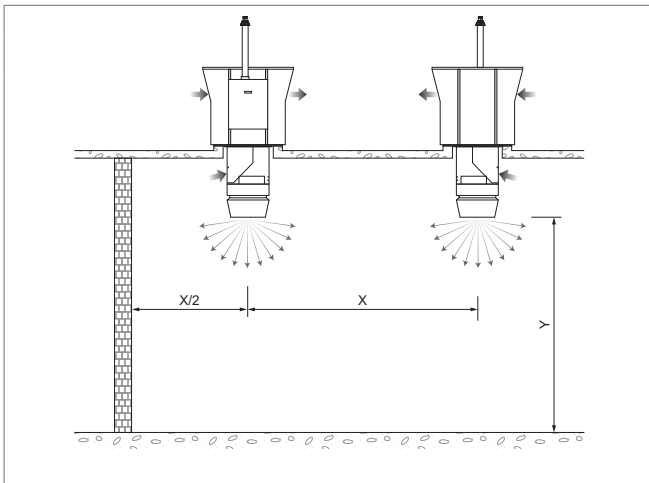

Distance X	min.	m	13
	max.	m	28
Mounting height Y	min.	m	5
	max. ¹⁾	m	Approx. 9...25

1) The maximum mounting height varies depending on the boundary conditions (for values, see table of heat outputs or calculation with the 'HK-Select' selection program)

Table 16: Minimum and maximum distances

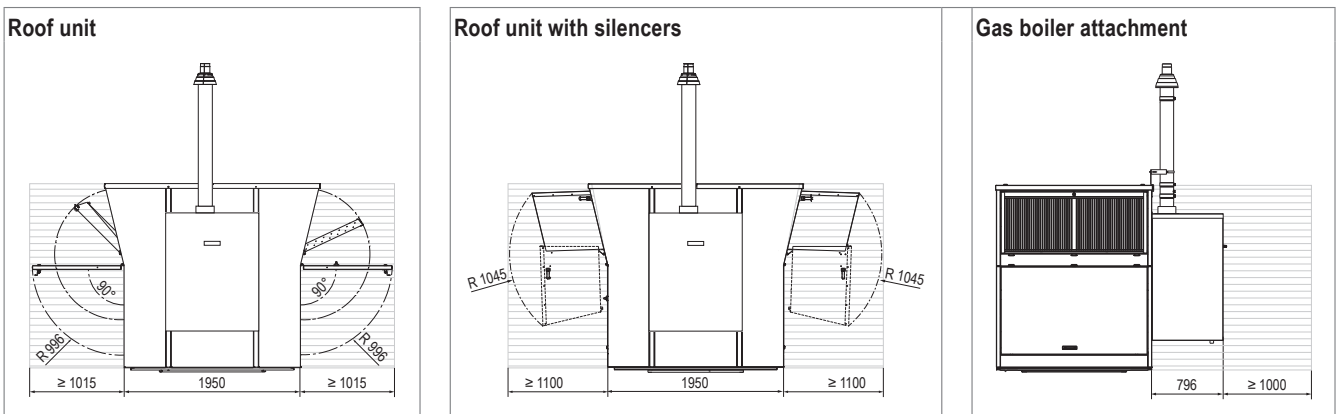

Fig. 9: Space requirements for maintenance on the roof (dimensions in mm)



Notice

If side access is not possible, proportionally more space is required for opening the access doors.

7.4 Installation



Caution

Risk of injury caused by falling load and improper handling. During installation:

- Wear personal protective equipment.
- Do not stand under suspended loads.
- Use cranes or forklifts with sufficient load-bearing capacity.



Caution

Provide suitable protective devices and make sure the units can be accessed easily. The maximum roof load of the RoofVent® units is 80 kg.

Preparation

- The units are assembled from roof level. Make sure that the following items are on hand for the assembly:
 - Crane for installing the below-roof unit
 - Crane or helicopter for assembly on the roof
 - Ladder for screwing in the transport eyes and for mounting the flue gas pipe
 - Lifting gear (minimum length of the lifting ropes: 2 m for the below-roof unit, 3 m for the roof unit)
 - Sealing compound for the roof frame (e.g. Sikaflex® 221)
 - Adhesive for securing screws (e.g. Loctite® 243, medium strength, soluble)
- Below-roof unit:
 - Remove the below-roof unit from the packaging film.
 - Remove the mounting bracket or wooden slats with which the below-roof unit is fixed to the pallet.
- Roof unit:
 - Remove the roof unit from the packaging film.
 - Open the extract air access door.
 - Behind this, loosen what is fixing the unit to pallet (2 screws).
 - Open the supply air access door.
 - Unscrew the fan protecting plate; this is only reattached when the unit is installed on the roof.
 - Behind the fan protecting plate, loosen what is fixing the unit to the pallet (2 screws).

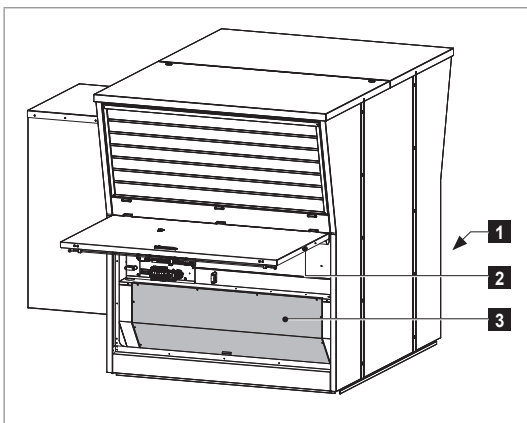

- 1 Extract air access door
- 2 Supply air access door
- 3 Fan protecting plate

Fig. 10: The fan protecting plate is temporarily attached with 4 screws during delivery.

Assembling the below-roof unit

The below-roof unit must only be assembled at the building site if it must be delivered in multiple parts due to the unit version. Proceed as follows:

- Make sure that the correct unit components match up (observe the unit number and RoofVent® serial number).
- Screw in the transport eyes into the connection module frame and attach the lifting gear.
- Lift the connection module complete with mounted components and rotate it into the correct position.



Notice

Never change the orientation of the supply air silencer (option) relating to the component above it. The correct position is marked on the unit.

- Place the connection module on the bottom part.
- Screw the components together; use the supplied screws and protective plugs to do so.

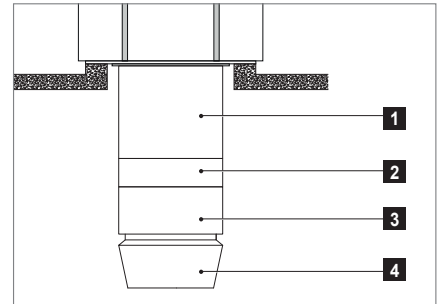

- 1** Connection module
- 2** Heating section
- 3** Supply air silencer (option)
- 4** Air-Injector

Fig. 11: Components of the below-roof unit

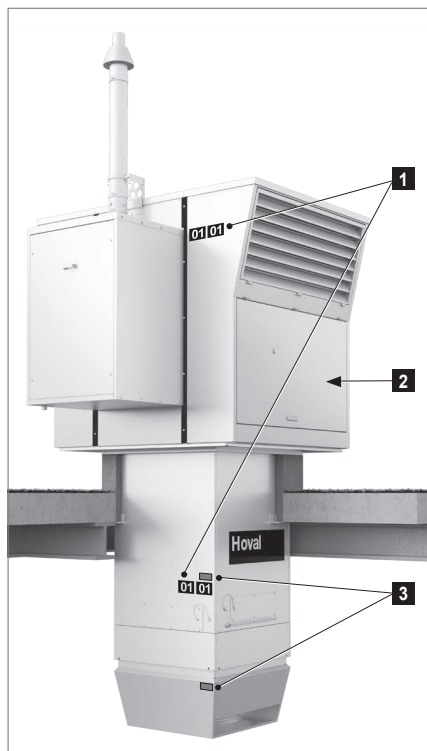

- 1** Unit number
- 2** Type plate with serial number (behind the access door)
- 3** Serial number

Fig. 12: Identification of the unit components



Fig. 13: Transport eye

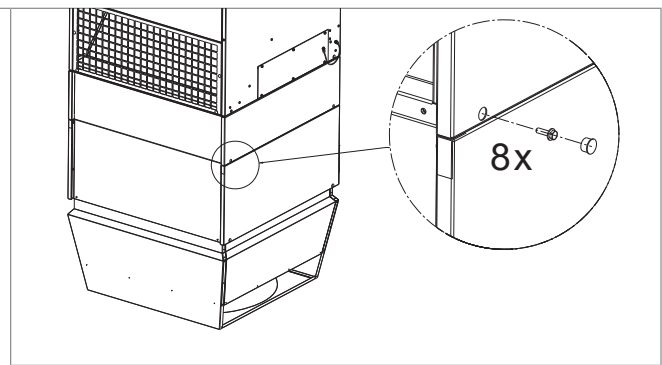

Fig. 14: Below-roof unit screw connection with M6 x 20 screws and protective plugs (8 per component)

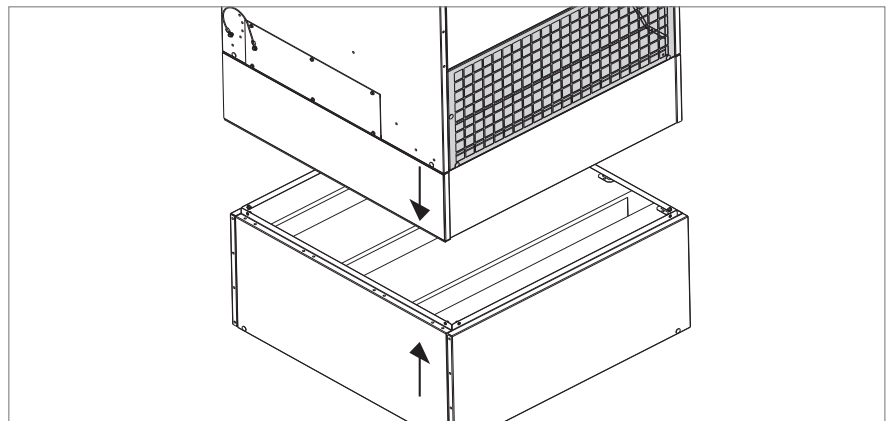
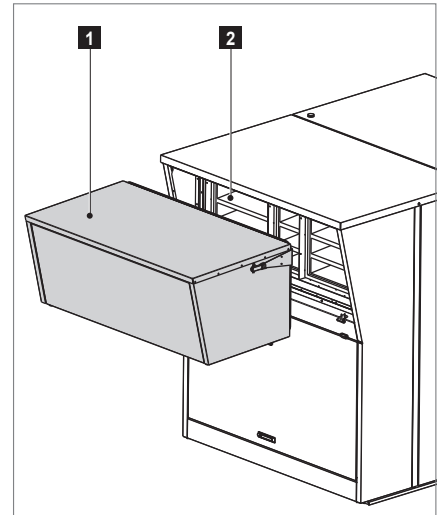

Fig. 15: Correct orientation of the supply air silencer: Sound attenuation splitters parallel to the extract air grille

Installing fresh air and exhaust air silencers

Fresh air and exhaust air silencers (optional) are supplied separately and must be installed on the roof unit at the building site. The installation material is provided. Proceed as follows:

- Fresh air silencer
 - Lift the silencer and position it on the air inlet opening of the unit.
 - Insert the bolts into the hinges and insert the safety washers.
 - Fold the silencer up and hook the clamping lock in on both sides.
 - Secure the clamping locks with cotter pins.
- Exhaust air silencer
 - Lift the silencer and position it on the air outlet opening of the unit.
 - Insert the bolts into the hinges and insert the safety washers.
 - Fold the silencer up and hook the clamping lock in on both sides.
 - Secure the clamping locks with screws.



1 Fresh air silencer
2 Fresh air filter

Fig. 17: Air inlet opening

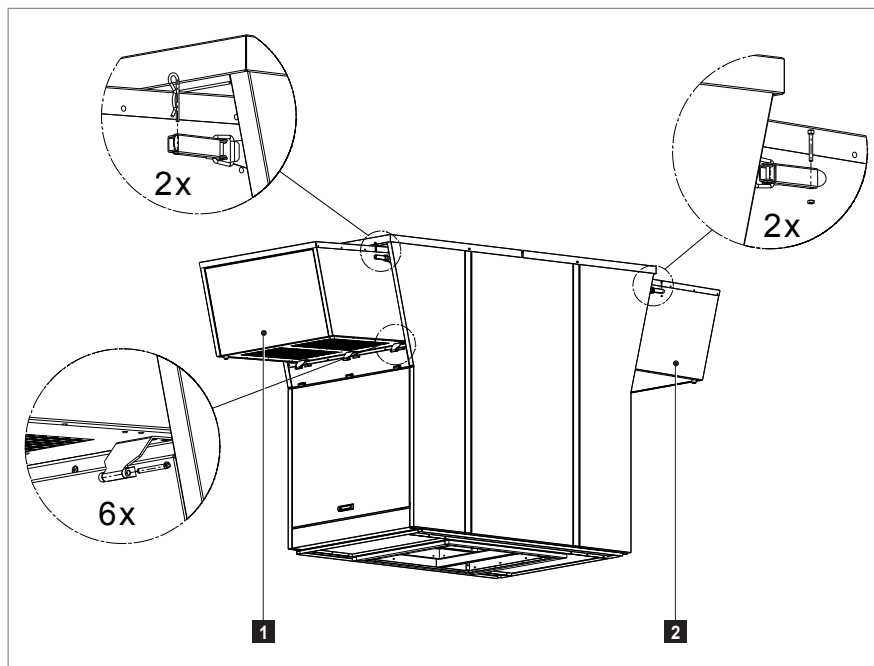

1 Fresh air silencer
2 Exhaust air silencer

Fig. 16: Installing fresh air and exhaust air silencers

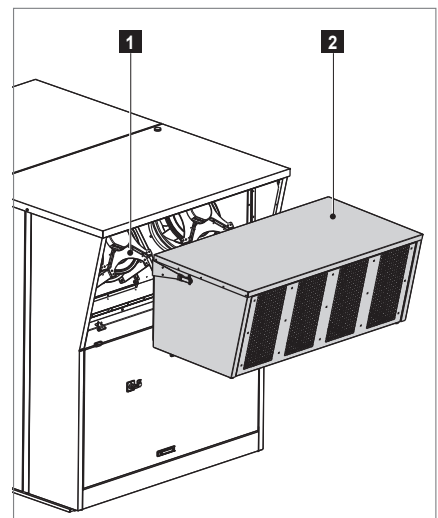

1 Exhaust air fan
2 Exhaust air silencer

Fig. 18: Air outlet opening

Installing the below-roof unit

- Apply sealing compound to the roof frame.
- Screw in the transport eyes into the connection module frame and attach the lifting gear.
 - Heed the minimum length of the lifting ropes (see Fig. 19).
- Transport the below-roof unit to the roof frame using a helicopter or crane.
- Turn the below-roof unit to the desired position.
- Hang the below-roof unit into the roof frame from above.
- Check the sealing strip on the connection module flange. Improve the seal if necessary.
- Remove the transport eyes.

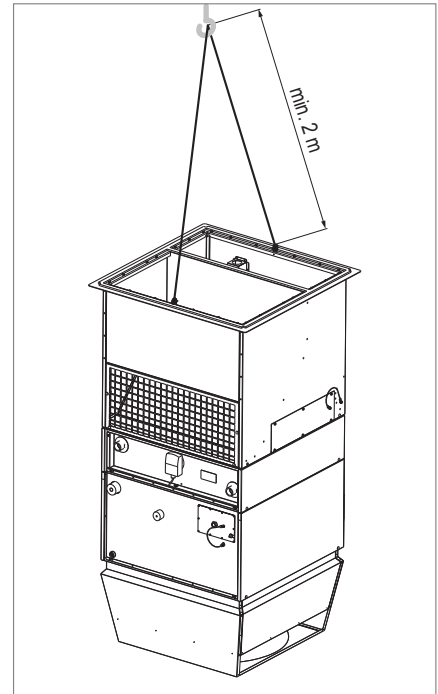

Fig. 19: Minimum length of the lifting ropes

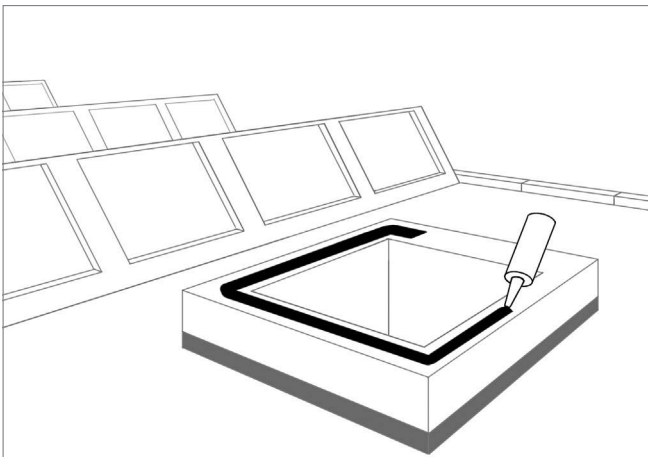

Fig. 20: Applying sealing compound to the roof frame

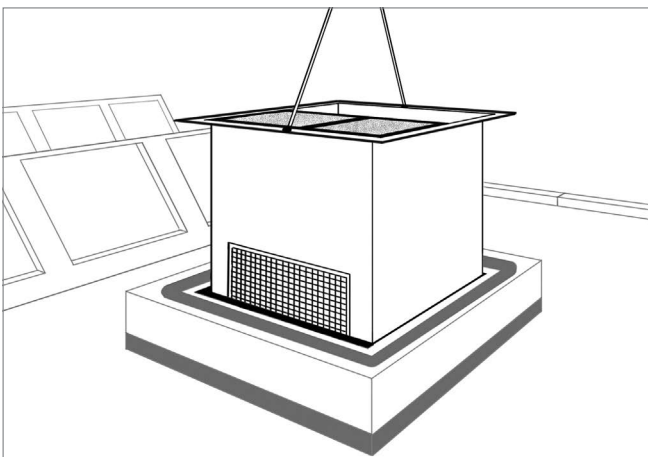

Fig. 21: Hanging the below-roof unit

Installing the roof unit

- Remove the cover caps on the unit roof.
- Screw in the transport eyes and attach the lifting gear.
 - Heed the minimum length of the lifting ropes (see Fig. 22).
- Transport the roof unit onto the roof.
- Open the supply air access door and the exhaust air access door and position the roof unit correctly in relation to the below-roof unit, placing the roof unit on top of the below-roof unit. The centring bolts on the connection module support the correct positioning.
- Screw the roof unit to the below-roof unit:
 - To do this, use the supplied M6 x 30 screws.
 - Secure the screw connection using medium-strength, soluble adhesive (e.g. Loctite® 243).
- Remove the transport eyes and attach the cover caps.
 - Keep the transport eyes for when disassembling the units at a later date at the end of their service life.
- Reattach the fan protecting plate on the supply air side:
 - Temporarily screw the protecting plate tight using 4 M5 x 16 screws; it must be removed again for electrical installation later.



Attention

Risk of damage to the unit due to condensation. If the electrical installation is not carried out until the next day or later and cold weather is to be expected: Tighten the fan protecting plate with all screws to prevent condensation.

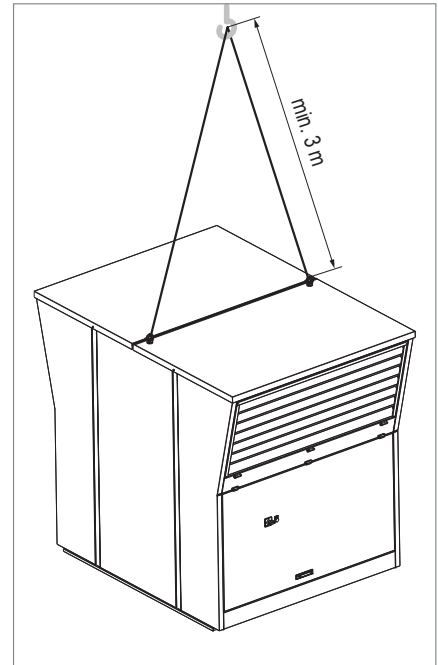
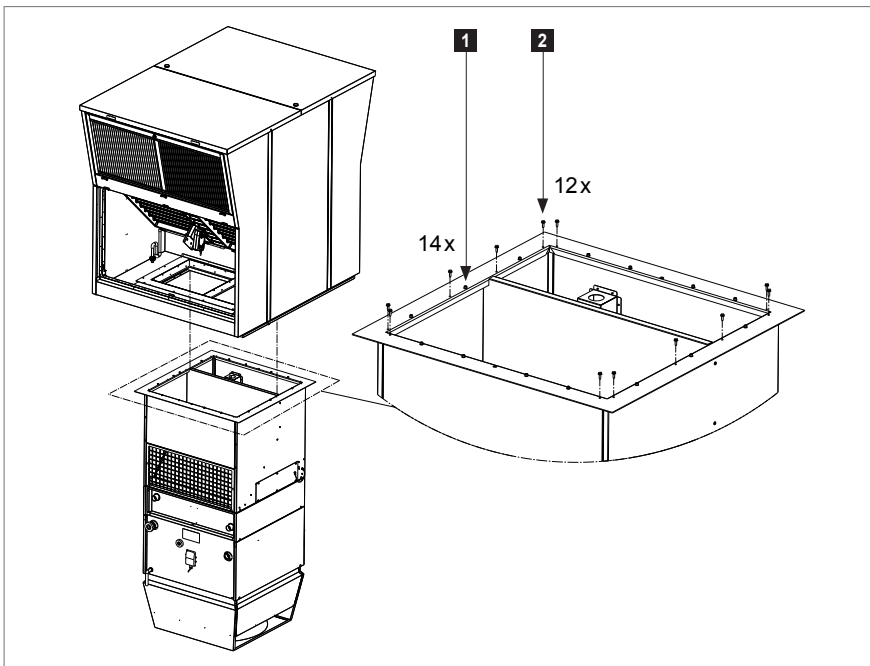

Fig. 22: Minimum length of the lifting ropes



1 Centring bolts

2 M6 x 30 screws

Fig. 23: Placing and screwing the roof unit

7.5 Installing the air intake/flue gas system

- Connect the loosely supplied parts of the air intake/flue gas pipe to each other (slip-on coupling with locking band and seal).
- Screw the spacer to the fastening bracket:
 - M6x20 screws with lock washers (2 ×)
- Screw the fastening bracket to the roof unit:
 - M6x20 screws (3 ×)
- Mount the air intake/flue gas pipe on the pre-installed first pipe section.
- Secure the air intake/flue gas pipe to the roof unit with the spacer.

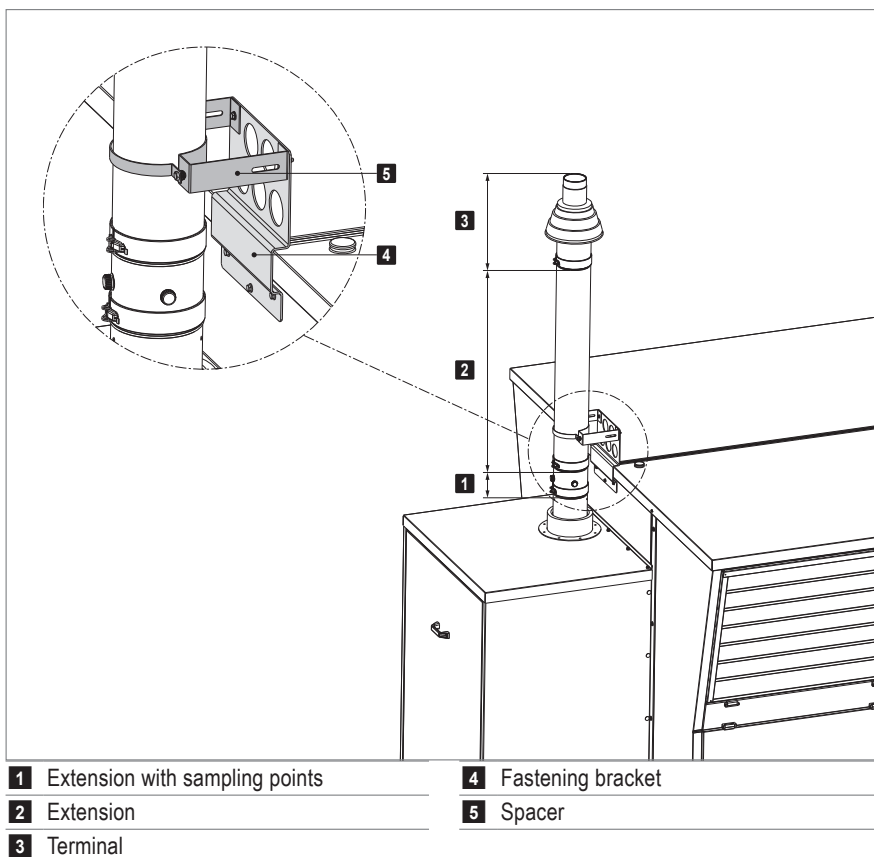

Fig. 24: Fastening the air intake/flue gas pipe

7.6 Connecting air ducts and Air-Injectors



Attention

Danger of damaging the units. The unit must not be subjected to the weight of the ducts. Suspend the ducts from the ceiling or support them on the floor.

Connecting the supply air duct

- Connect RoofVent® units without Air-Injectors or with 2 Air-Injectors to a on-site air duct.
- For units with 2 Air-Injectors: Install the two Air-Injectors on the supply air duct:
 - Stick the compression tape onto the Air-Injectors.
 - Attach the Air-Injectors to the supply air duct with a perforated angle plate and blind rivet nuts.
 - Do not install any add-ons or fittings in the direct outlet area. The supply air jet must be free to spread out unhindered.

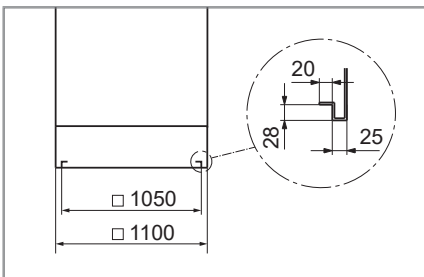

Fig. 25: Connection dimensions supply air duct (in mm)

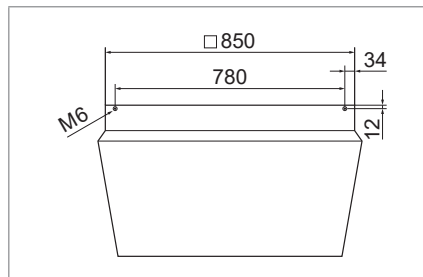
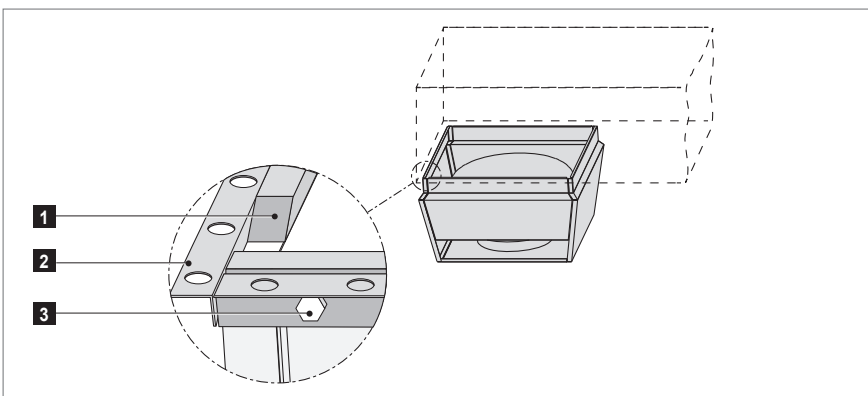

Fig. 26: Hole pattern for Air-Injector (dimensions in mm)



- 1 Compression tape (on site)
- 2 Perforated angle plate (on site)
- 3 Blind rivet nuts (on site)

Fig. 27: Installing the Air-Injectors on the supply air duct

7.7 Hydraulic installation

The complete heating circuit is already integrated in RoofVent® RG units. The following work must be carried out during installation:

- Connect the flow and return pipes of the below-roof unit to the connections in the roof unit:
 - To do this, use the metal tubes supplied loose (connections: external thread R 1¼" / internal thread Rp 1¼").
 - Seal the pipe connection with hemp or thread seal tape.
- Make sure that the drain tap in the heating section is closed.
- Check the inlet pressure in the diaphragm expansion vessel.
 - Inlet pressure: 100 kPa (at 20 °C)
- Fill the heating circuit with the supplied heat transfer fluid.
 - Operating pressure: min. 200 kPa (at 20 °C)



Attention

Risk of damage to the unit due to incorrect heat transfer fluids in the heating circuit. Use only the provided heat transfer fluid.

- Bleed the heating circuit.
- Check the heating circuit for leaks.

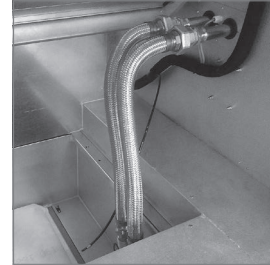

Fig. 28: Connecting the heating circuit

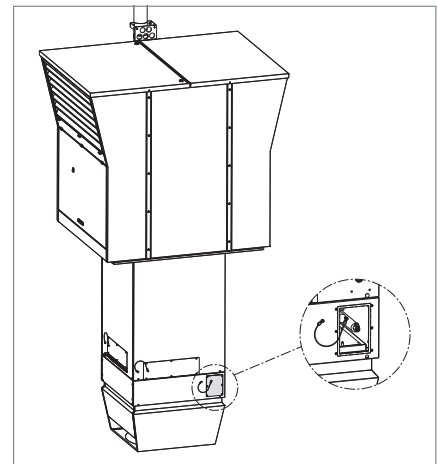

Fig. 29: Position of the drain tap behind the access panel in the heating section

7.8 Condensate connection

The condensate from the gas condensing boiler is neutralised and flows off through the condensate drain on the underside of the gas boiler attachment.

- Install a condensate drain in accordance with the local provisions.
 - Plug connection: DN 40
- To avoid icing:
 - Run the condensate line through the roof into the building by the most direct route possible.
 - Insulate the outdoor part of the condensate line.

Condensate drain line with 'condensate drain inside' option

The condensate from the gas condensing boiler is channelled inside the Roof-Vent® unit to the drain connection in the connection module.

- Connect the drain hose of the roof unit with the drain hose of the below-roof unit, fix the connection with a hose clamp and mount the drain connection in the connection module.
- Install a condensate drain in accordance with the local provisions.
 - Connection: External thread G ¾"

7.9 Gas connection

**Caution**

Risk of injury from incorrect handling. Gas connection must be carried out by trained specialists only!

Please note the following:

- The fuel used is natural gas. Check the type of gas the unit is set to work with and, if necessary, have Hoval Customer Service reset the unit to the type of gas supplied locally.
- During operation of the unit, the required quantity of gas and the necessary pressure of gas must be present constantly.
 - Gas flow pressure: 17.4 – 50 mbar
- An opening is provided on the underside of the gas boiler attachment for the gas supply line.
- Ensure that the gas supply line run and the dimensions are in compliance with the relevant local regulations.
 - Connection: External thread R ¾"
- Connect the gas supply line with appropriate bolted joints which can be loosened, tension-free and vibration-free (gas hose, compensator).
- The connection of the unit to the gas supply line must be gas-tight.
- Install a gas shut-off valve in the gas supply line immediately upstream of the unit, as well as other components required by local regulations, such as gas filter, gas pressure regulator, pressure gauge with push-button tap, etc. (not included in the scope of delivery).
- Clean the inside of the gas supply pipe before connecting it to the unit.

7.10 Electrical installation



Caution

Danger of electric shocks. The electrical installation must only be carried out by a qualified electrician.

Please note the following:

- Observe all relevant regulations (e.g. EN 60204-1).
- Choose the dimensions of the cable cross sections in line with the applicable regulations.
- Route signal and bus lines separately from mains cables.
- Make sure the lightning protection system for the units or for the entire building is planned and carried out by professionals.
- Provide overload protection equipment on site in the mains connection line of the zone control panel.
- Carry out the electrical installation according to the wiring diagram.
- Secure all connections against working loose.
- When installing cables, observe the following points:
 - Fasten the cables in place with cable mounts and cable ties or with cable conduits/ducts.
 - Use blind rivets.
 - Drill holes with a maximum diameter of 5 mm Ø.
 - The maximum drilling depth is 10 mm. Use a drill bit with a depth stop.
 - The maximum load resulting from cable holders and cable guides is 10 kg.
 - All access panels must be easily removable.
 - Do not drill any holes in the connection module around the connection box and cable duct leading to the roof unit.

Proceed as follows:

- Connect the connection box in the below-roof unit to the control block in the roof unit.
 - Unscrew the fan protecting plate.
 - Detach the wiring harness from the below-roof unit frame.



Attention

Danger of damaging the unit: Dropping the cables may damage the heating coil. Detach the wiring harness carefully.

- Pull the wiring harness upwards and fasten it using a cable bushing and a cable clamp.
- Depending on the length of the connection module, the wiring harness has a little excess length. Fix it with the cable clamps in the roof unit (Fig. 30).
- Connect the cable to the control block according to wiring diagram.
- Screw the fan protecting plate tightly again. To do this, use the supplied M5 x 16 screws.
- Connect the power supply to the connection box.
- Connect the zone bus to the connection box.
- Connect the unit frame with the foundation earth electrode and attach an earthing label.
- Connect the electrical components of the below-roof unit to the connection box (see Fig. 31).

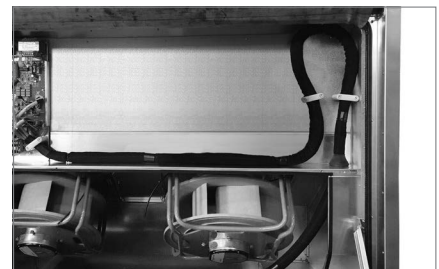
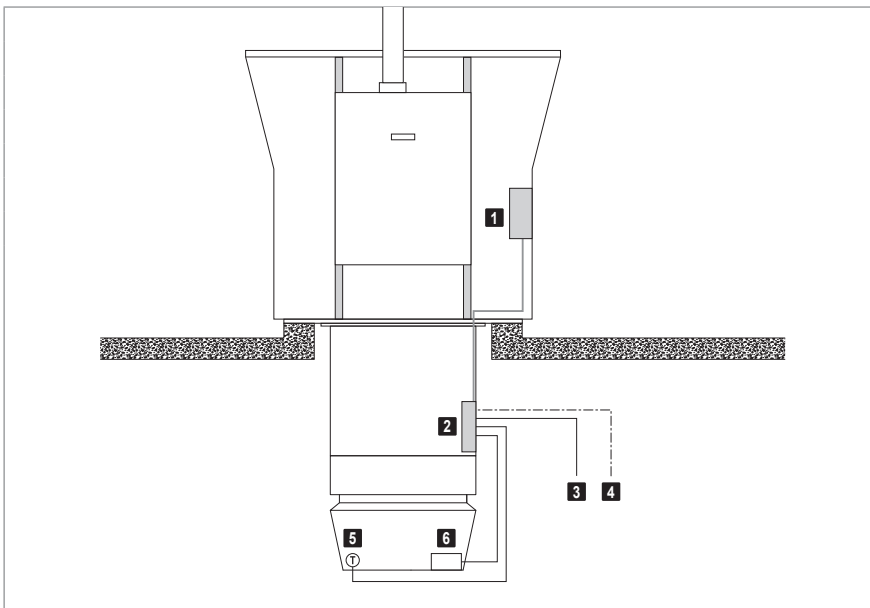

Fig. 30: Fixing the wiring harness in the roof unit

Options

- Design with 2 Air-Injectors:
 - Install the enclosed supply air temperature sensor in the supply air duct and wire it up to the connection box.
 - Wire up both actuators to the connection box.
- Design without Air-Injector:
 - Install the enclosed supply air temperature sensor in the supply air duct and wire it up to the connection box.



- | | |
|---|-------------------------------|
| 1 | Control block |
| 2 | Connection box |
| 3 | Zone bus |
| 4 | Power supply RoofVent® |
| 5 | Supply air temperature sensor |
| 6 | Actuator Air-Injector |

Fig. 31: On-site electrical connection (components vary depending on unit type)

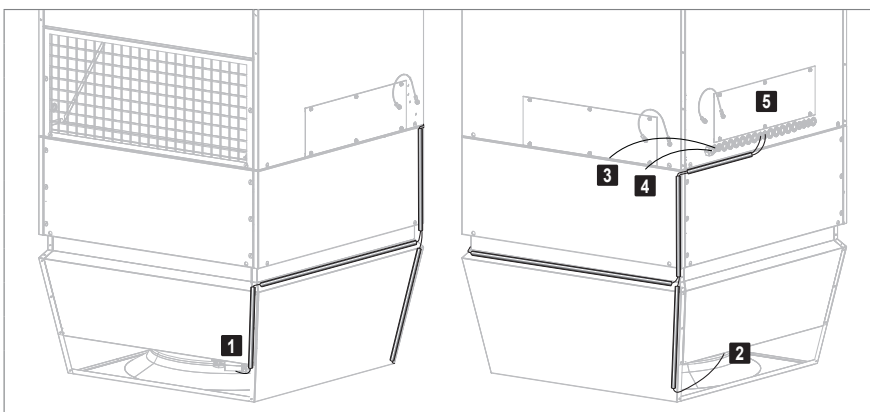

- | | |
|---|-------------------------------|
| 1 | Actuator Air-Injector |
| 2 | Supply air temperature sensor |
| 3 | Power supply RoofVent® |
| 4 | Zone bus |
| 5 | Connection box |

Fig. 32: Cable routing on the below-roof unit (components vary depending on unit type)

Temperature sensors

The room air sensor and the fresh air temperature sensor are supplied loose in the control panel:

- Install the room air temperature sensor at a representative position in the occupied area at a height of about 1.5 m. The measured values must not be distorted by the presence of sources of heat or cold (machines, direct sunlight, windows, doors, etc.).
- Install the fresh air temperature sensor at least 3 m above the ground on a north-facing wall, so that it is protected from direct sunlight. Provide cover for the sensor and thermally insulate it from the building.

8 Operation

8.1 Initial commissioning

**Attention**

Risk of damage to property as a result of performing initial commissioning on your own authority. Initial commissioning must be performed by the manufacturer's customer service technicians.

Checklist to prepare for commissioning:

- Mechanical installation
 - Indoor climate units
 - Zone control panels
 - Operator terminals
- Gas installation
 - Gas supply line and gas connection
 - Flue gas evacuation and combustion air supply
 - Compliance with all relevant regulations
 - Approval of the local building authority
- Electrical installation
 - Power supply for indoor climate units, zone control panels
 - Laying of bus cables conforming to wiring diagram
 - Installation and wiring of all sensors (room temperature sensor, fresh air sensor, ...)
 - Wiring of external operator terminals
 - Wiring of external inputs and outputs
- Organisational matters
 - Access to all system components during commissioning (indoor climate units, operator terminals, ...)
 - Provision of a suitable working platform
 - Organisation of commissioning and training (date, presence of all of the respective trade groups and of the operating personnel)

The unit is checked at the factory and preset according to the specifications on the type label.

8.2 Operation

The system runs fully automatically depending on the programmed operating times and temperature conditions.

- Observe the operating instructions for the control system.
- Check alarm displays daily.
- Correct changes to operating times in the programming accordingly.
- Ensure free air outlet and unhindered dispersion of the supply air.

9 Maintenance and repair



Caution

Risk of injury from incorrect work. Maintenance work must be carried out by trained personnel.

9.1 Safety

Before performing any work on the unit:

- Switch off heating operation (operating mode 'L_OFF').
- Close the cut-off valve in the gas supply line.
- Let the unit cool off. The heating pump continues to run to cool down the heat exchanger.



Attention

Fire hazard due to hot components. Do not switch off the power supply until the heating pump comes to a complete stop!

- When the heating pump comes to a stop: Turn the isolation switch on the unit to the 'Off' position and secure it against being switched back on.



Caution

Danger of electric shocks. The unit controller and the service socket are still live.

- Wait at least 3 minutes after switching the unit off.



Caution

The use of condensers can pose a danger of fatal injury from directly touching live parts even after the unit is switched off. Only open the access doors after waiting 3 minutes.

- Observe the accident prevention regulations.
- Observe the particular dangers involved when working on electrical systems.
- When working in the unit, take precautions against unprotected, sharp metal edges.
- Immediately replace damaged or removed informational and warning signs.
- Following maintenance work, professionally reassemble all dismantled protective devices.
- Replacement parts must comply with the technical requirements of the unit manufacturer. Hoval recommends the use of original spare parts.



Fig. 33: Position of the isolation switch behind the supply air access door

9.2 Maintenance

Maintenance schedule

Activity	Procedure	Interval
Clean unit	<ul style="list-style-type: none"> ■ Clean inside of RoofVent® unit with vacuum cleaner. ■ Clean the heat exchanger and burner of the gas condensing boiler. ■ Remove the siphon, clean it and rinse the condensate drain. 	1 × annually
Functional check	<ul style="list-style-type: none"> ■ Check function of the fan and actuators. ■ Check function of the Air-Injector. ■ Check the connections of the gas condensing boiler for leaks. ■ Check ignition electrode and readjust or replace if necessary. ■ Check function of the control system. 	1 × annually
Flue gas path test	<ul style="list-style-type: none"> ■ Check flue gas pipe and, if required, clean inside. 	1 × annually
Emission measurement	<ul style="list-style-type: none"> ■ Check setting of the gas control valve and readjust where necessary. 	1 × annually
Neutraliser	<ul style="list-style-type: none"> ■ Loosen contaminated granulate and clean neutralisation unit with water. Replace heavily soiled granulate. 	1 × annually
Check of the heat transfer fluid	<ul style="list-style-type: none"> ■ Check the system pressure and top up with heat transfer fluid if necessary. ■ Take sample and test: <ul style="list-style-type: none"> – Test pH value with indicator strips – Test frost protection with a refractometer 	1 × annually
Filter change	<ul style="list-style-type: none"> ■ Renew air filter. <ul style="list-style-type: none"> – Filter set Fresh air Mat.no. 6046474 – Filter set Extract air Mat.no. 6056884 	When the filter alarm is displayed, at least 1× annually
Test of the inhibitor protection	<ul style="list-style-type: none"> ■ Take a sample of the heat transfer fluid and have the inhibitor protection analysed by a suitable service provider. 	Every 3 years

Table 17: Maintenance schedule

Changing the filter



Caution

Danger of hazardous emissions from damaged filters:

- Only hold the filters on the black filter frame.
- Never touch the white filter medium.
- Replace damaged filter elements immediately.



Caution

Crushing hazard from closing dampers. Only open the access doors when the 'Filter change' illuminated button is constantly illuminated (waiting period of approx. 2 min).

- Press the 'Filter change' illuminated button.
- Wait until the button is constantly illuminated.
 - The button flashes whilst the speed of rotation of the fans is reduced and the dampers close; it illuminates constantly as soon as the access doors may be opened.
- Changing the extract air filter:
 - Open the extract air access door.
 - Release the filter brackets and remove the filter elements.
 - Insert the new filter elements. When doing this, only hold the frame.
 - Fix the filter elements in place with the filter brackets.
 - Close the access door.
- Changing the fresh air filter:
 - Open the fresh air access door. Release the safety loops and fold the access door down completely.
 - Release the filter brackets and remove the filter elements.
 - Insert the new filter elements. When doing this, only hold the frame.
 - Fix the filter elements in place with the filter brackets.
 - Fold the access door up and reattach the safety loops. Close the access door.
- Changing the fresh air filter when a fresh air silencer is installed:
 - Open the clamping lock of the fresh air silencer on both sides. Fold the silencer down.
 - Release the filter brackets and remove the filter elements.
 - Insert the new filter elements. When doing this, only hold the frame.
 - Fix the filter elements in place with the filter brackets.
 - Fold the silencer up and hook the clamping lock in on both sides. Secure the clamping locks with cotter pins.
- Press the 'Filter change' illuminated button again to set the unit back to normal operation. The button goes out.



Notice

If the 'Filter change' illuminated button is not pressed again, the unit automatically switches back to normal operation after 30 min. The button goes out.

- Dispose of the filters in accordance with local regulations.
 - The filters are fully incinerable; the disposal of used filters depends on the contents.

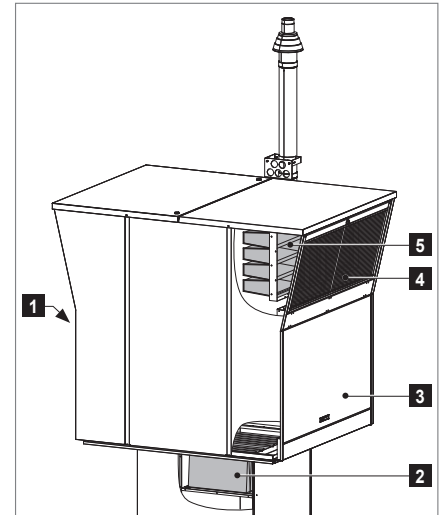

- 1 Filter change illuminated button
- 2 Extract air filter
- 3 Extract air access door
- 4 Fresh air access door
- 5 Fresh air filter

Fig. 34: Changing the filter

9.3 Repair

If required, contact Hoval customer service.

Product service life

Component	Service life
EC motors of the supply air and exhaust air fans	approx. 30'000 to 40'000 hours depending on the application and environmental conditions
Damper actuators with spring return	at least 60'000 emergency positions

Table 18: Product service life

10 Dismantling



Caution

Risk of injury caused by falling load and improper handling.

- Wear protective equipment (fall protection, helmet, safety shoes).
- Do not stand under suspended loads.
- Use cranes or helicopters with sufficient load-bearing capacity.
- Do not lift the two-part unit in one piece.

- Close the cut-off valve in the gas supply line.
- Disconnect the power supply to the unit.
- Wait at least 3 minutes after switching the unit off.



Caution

The use of condensers can pose a danger of fatal injury from directly touching live parts even after the unit is switched off. Only open the access doors after waiting 3 minutes.

- Empty the heating circuit.
- Dismantle all media connections.
- Dismantle the flue gas pipe.
- Disconnect the unit from any fastenings.
- Open the supply air access door and the extract air access door.
- Unscrew the fan protecting plate.
- Disconnect the screw connection between the roof unit and below-roof unit.
- Remove the cover caps on the unit roof.
- Screw in the transport eyes and attach the lifting gear.
- Remove the roof unit.
- Screw in the transport eyes into the connection module frame and attach the lifting gear.
- Remove the below-roof unit.

11 Disposal

- Recycle metal components.
- Recycle plastic parts.
- Recycle the heat transfer fluid.
- Dispose of electric and electronic parts via hazardous waste.
- Dispose of oil-fouled parts in accordance with local regulations.
- Dispose of the filters in accordance with local regulations.
 - The filters are fully incinerable; the disposal of used filters depends on the contents.

International

Hoval Aktiengesellschaft
9490 Vaduz
Liechtenstein
Tel. +423 399 24 00
info.klimatechnik@hoval.com
www.hoval.com

United Kingdom

Hoval Ltd.
Northgate, Newark
Notts
NG24 1JN
Tel. 01636 672711
hova1@hova1.co.uk
www.hova1.co.uk