

Hoval MultiVal ESRR (500-1000)

Calorifier with large heat exchanger on the top for multivalent heating

Description

Hoval

Hoval calorifier

MultiVal ESRR (500)

- Calorifier made of steel enamelled inside
- 2 smooth pipe heat exchangers enamelled, built in
 - at the bottom: for solar use
 - for heating with heat pumps
- Magnesium protection anode or impressed current anode built in
- Flange for electric heating element
- Thermal insulation made of polyurethane hard foam hulls, foamed on the calorifier, dismantable foil casing, colour red
- Sensor channel
- Immersion sleeve welded in
- With thermometer
- 1½" sleeve for a screw-in electric heating element

Delivery

- Calorifier fully cased

On request

- Flange-mounted electric heating element

Hoval calorifier

MultiVal ESRR (800-1000)

- Calorifier made of steel enamelled inside
- 2 smooth pipe heat exchangers enamelled, built in
 - at the bottom: for solar use
 - for heating with heat pumps
- Correx® potentiostat included
- 2 impressed current anodes incl. connecting cable integrated
- Flange below as cleaning flange or for the installation of a flange-mounted electric heating element or blank flange with immersion sleeve
- Flange above as additional cleaning flange or for the installation of a flange-mounted electric heating element
- Thermal insulation made of polyester fleece with foil jacket, colour red
- Two terminal bars for contact sensor
- With thermometer

Delivery

- Calorifier and thermal insulation completely installed (can be removed for installation)

On request

- Flange-mounted electric heating element



Range

MultiVal type

ESRR	(500)	B ▶
ESRR	(800)	
ESRR	(1000)	

Calorifier



MultiVal ESRR (500-1000)

Made of steel enamelled, with 2 heat exchangers
MultiVal ESRR (500) fully cased.
MultiVal ESRR (800,1000) calorifier and thermal insulation delivered separately packed.

MultiVal ESRR type	Volume dm ³	Heating surface m ²	
		top	bottom
(500)	B 463	4.30	2.15
(800)	731	5.20	2.60
(1000)	958	6.10	3.40

Part No.

7016 754
7018 053
7018 054

Electric heating elements

see chapter "Electric heating elements"

Accessories



Flange cover 180 - 3/4"

for the installation of the Correx[®] impressed current anode in flange Ø 180/110 mm, enamelled on the inside with Rp 3/4" sleeve
Seal included

2077 035



Flange with immersion sleeve for temperature sensor made of steel on DHW side, enamelled inside.

Flange dimensions:
- Outer Ø 180 mm,
- Pitch circle Ø 150 mm, 8 x M10
Immersion sleeve dimensions:
- Installation length = 120 mm,
- Outer Ø: 24 mm, inner Ø: 20 mm

6028 468



Kit Correx[®] impressed current anode UP2.3-919-L395/1

for long-term corrosion protection for installation in the enamelled calorifier with reduction R 1 1/4" (ET) – Rp 1" (IT) and R 1" (ET) – Rp 3/4" (IT)
Installation length: 395 mm
Connection cable length: 1 x 2000 mm
1 Correx[®] impressed current anode

684 760

Included in the scope of delivery of ESRR (800,1000)

In every case, **either** a Correx[®] impressed current anode **or** one/two magnesium anodes are allowed to be used.

Part No.



Immersion sensor TF/2P/5/6T, L = 5.0 m with plug
 for TopTronic® E controller modules/
 module expansions with exception of
 basic module district heating/fresh
 water or basic module district heating com
 cable length: 5 m with plug
 sensor sleeve diameter: 6 x 50 mm
 dewpoint-proof
 operating temperature: -20...105 °C
 protection class: IP67

2056 788



Immersion sensor TF/2P/5/6T, L = 5.0 m
 for TopTronic® E controller modules/
 module expansions with exception of
 basic module district heating/fresh
 water or basic module district
 heating com,
 cable length: 5 m without plug
 sensor sleeve diameter: 6 x 50 mm,
 dewpoint-proof,
 operating temperature: -20...105 °C,
 protection class: IP67

2055 888



Immersion sensor TF/12N/2.5/6T, L = 2.5 m
 for gas boiler with RS-OT
 Cable length: 2.5 m
 Sensor sleeve diameter: 6 x 50 mm,
 dewpoint-proof,
 operating temperature: -20...105 °C,
 protection class: IP67

2056 791

At TopTronic® E, immersion sensor is included in the boiler controller or in the heating controller set.



Calorifier thermostat control TW 12
 Universal thermostat controller
 for thermostatic pump charge
 demand, setting in
 casing, visible from outside.
 15-95 °C, switching difference 6 K,
 capillar length 700 mm
 incl. fastening material for
 Hoval calorifier, can be used with
 integrated immersion sleeve

6010 080

Thermal water mixer
 see "Various system components"

Services



Commissioning
 Commissioning by works service or Hoval
 trained authorised serviceman/company is
 condition for warranty.

For commissioning and other services
 please contact your Hoval sales office.

MultiVal ESRR (500-1000)

Type		(500)	(800)	(1000)
• Volume	dm ³	463	731	958
• Volume (upper battery)	dm ³	235	444	535
• Operating pressure/test pressure	bar	10/13	10/13	10/13
• Max. operating temperature	°C	95	95	95
• Expanded PU hard foam thermal insulation	mm	75	-	-
• Thermal insulation λ	W/mK	0.027	0.04	0.04
• Polyester fibre fleece thermal insulation	mm	-	100	100
• Fire protection class		B2	B2	B2
• Heat loss at 65 °C	W	81	128	144
• Transport weight	kg	234	301	383
• U value	W/m ² K	0.333	0.38	0.375
Heating battery low (built in)		Plain tube heat exchanger for solar use		
• Heating surface	m ²	2.15	2.6	3.4
• Heating water content	dm ³	15.1	17.8	24.1
• Flow resistance ¹⁾ water	z value	3.6	4.5	7.5
• Flow resistance ¹⁾ water/glycol 50 %	z value	3.9	5.8	10
• Operating pressure/test pressure	bar	10/13	10/13	10/13
• Max. operating temperature	°C	110	110	110
• For flat collectors up to ²⁾	m ²	11	15	20
Heating battery up (built in)		Plain tube heat exchanger for heat pumps		
• Heating surface	m ²	4.3	5.2	6.1
• Heating water content	dm ³	30.1	36.1	42.6
• Flow resistance ¹⁾	z value	8	8	10
• Operating pressure/test pressure	bar	10/13	10/13	10/13
• Max. operating temperature	°C	110	110	110
• Dimensions		see table of dimensions		

¹⁾ Flow resistance heating battery in mbar = flow rate (m³/h)² x z (1 mbar = 0.1 kPa)

²⁾ Collector surface, related to the heat exchanger heating surface only

Performance figure

Selection of the calorifier type
at a hot water temperature of 45 °C

Reading example
see engineering

T >	Comfort ¹⁾			Standard ²⁾		
	60 °C	70 °C	80 °C	60 °C	70 °C	80 °C
NL v						
1						
2						
3						
4						
5						
6						
7						
8						
9	500					
10				500		
11						
12	800					
13	1000					
14				800		
15				1000		
16						
17		500				
18						
19			500			
20						
21				500		
22						
23						500
24		800				
25						
26		1000				
27			800			
28						
29						
30				800		
31			1000			
32						
33				1000		
34						800
35						
36						
37						
38						
39						
40						1000
41						
42						
43						
44						
45						
46						
47						
48						
49						
50						

T >	Comfort ¹⁾			Standard ²⁾		
	60 °C	70 °C	80 °C	60 °C	70 °C	80 °C
NL v						
51						
52						
53						
54						
55						
56						
57						
58						
59						
60						
61						
62						
63						
64						
65						
66						
67						
68						
69						
70						
71						
72						
73						
74						
75						
76						
77						
78						
79						
80						
81						
82						
83						
84						
85						
86						
87						
88						
89						
90						
91						
92						
93						
94						
95						
96						
97						
98						
99						
100						

T = heating flow

NL = performance figure

Performance figure NL acc. to DIN 4708 = number of flats which can be supplied with domestic hot water when the calorifier is heated and permanently reheated with the heat generator (standard flat: 1 bathroom - 4 rooms - 3.5 persons)

¹⁾ Calculation with simultaneity factor according to DIN 4708 (preferred for Switzerland)

²⁾ Calculation with simultaneity factor according to Dresden Technical University

10 min peak output/N number with domestic hot water 45 °C
according to DIN 4708 (Comfort) and Dresden Technical University (Standard)

Reading example
see Engineering

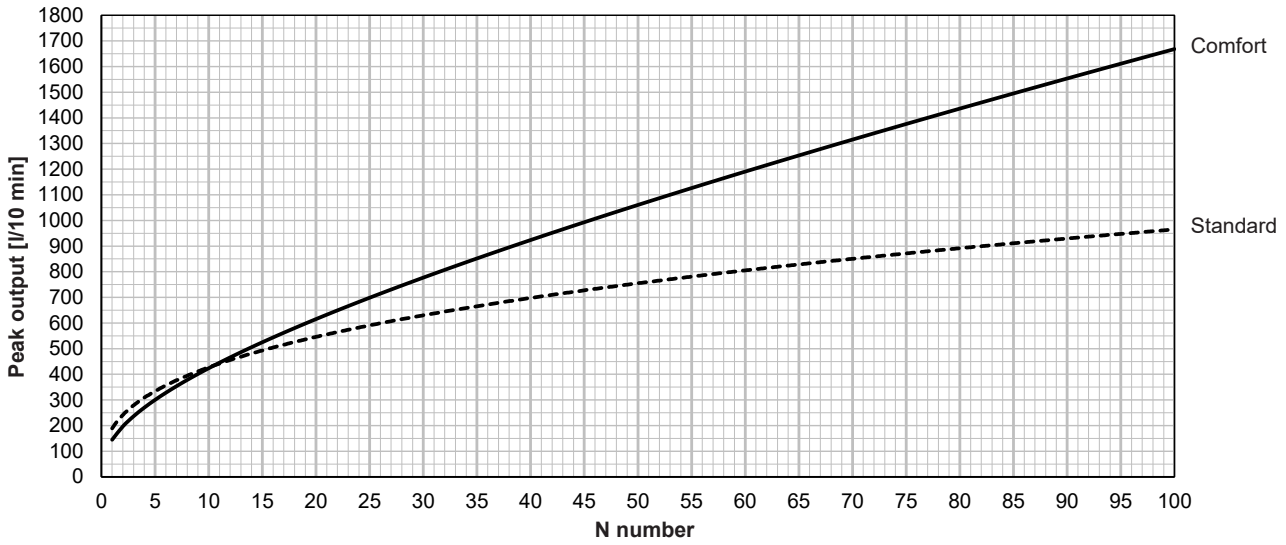

MultiVal ESRR (500)

Hot water output
Continuous output

Reading example
see engineering

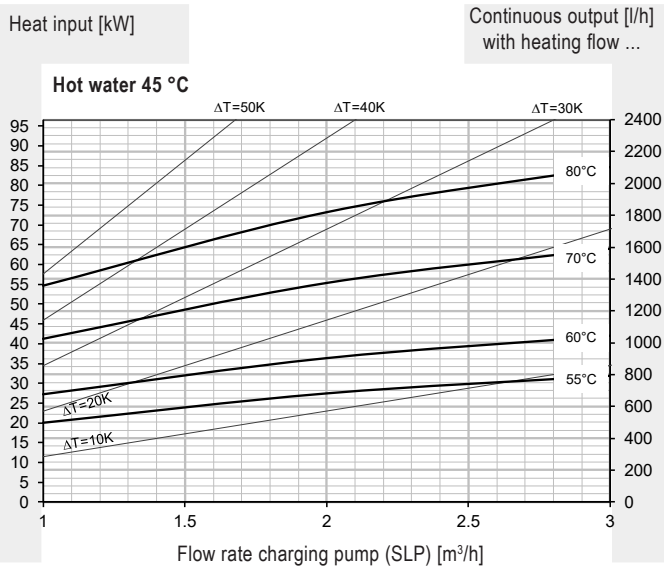

10 min peak output - hot water 45 °C *

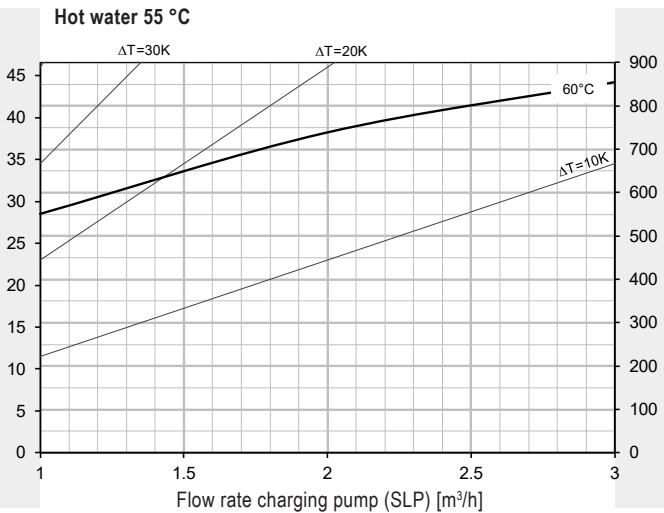
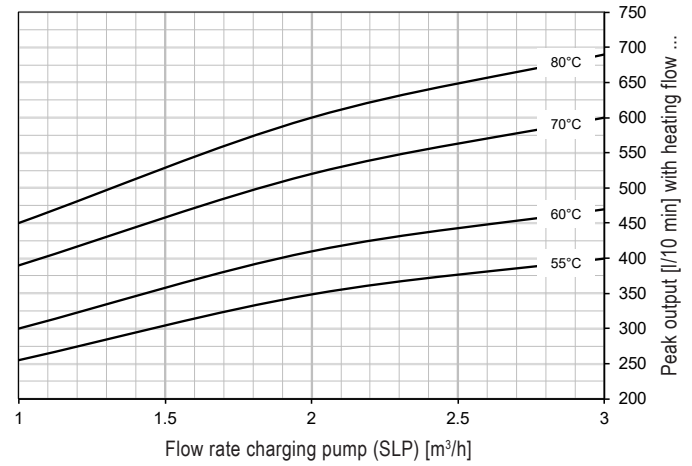

Pressure drop heating coil - delivery head charging pump

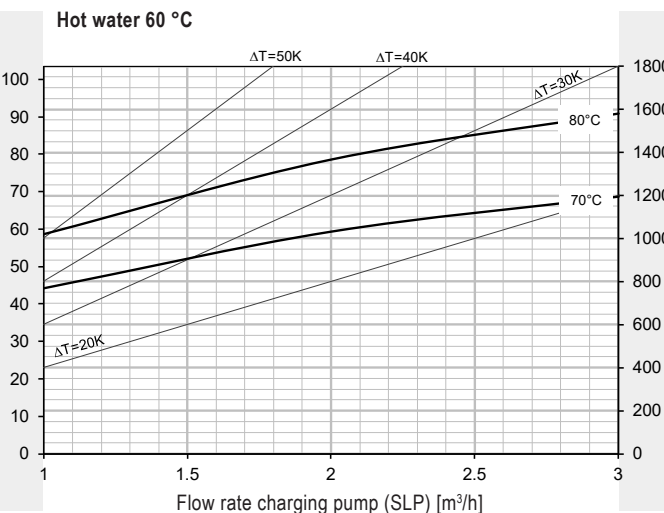
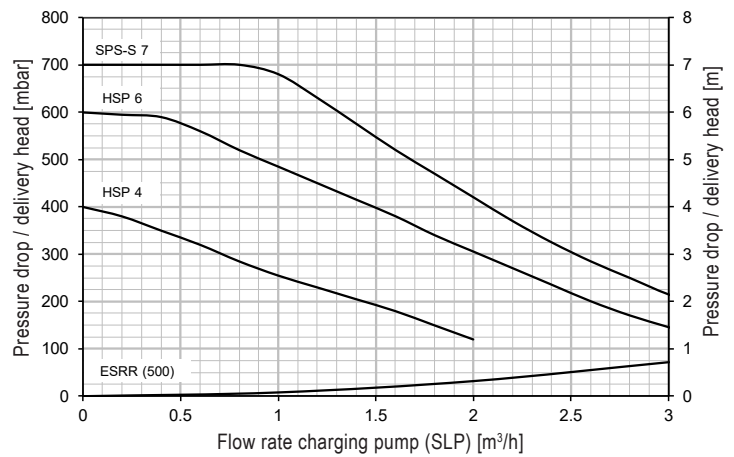

* Calorifier heated to 60 °C

MultiVal ESRR (800)

Hot water output
Continuous output

Reading example
see engineering

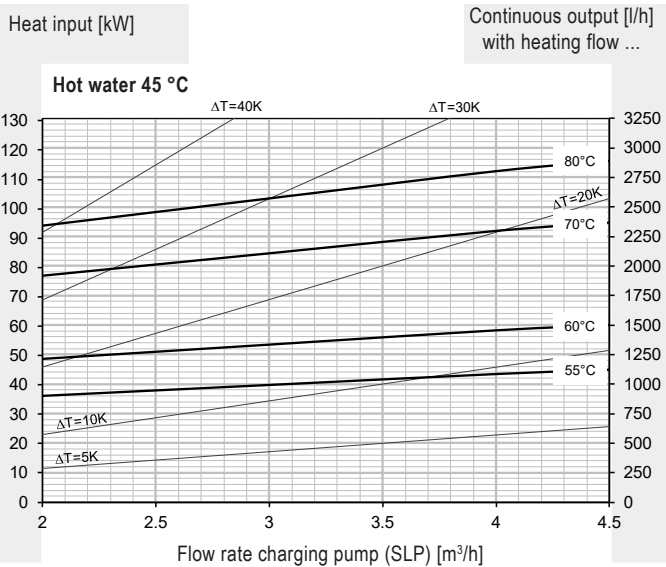

10 min peak output - hot water 45 °C *

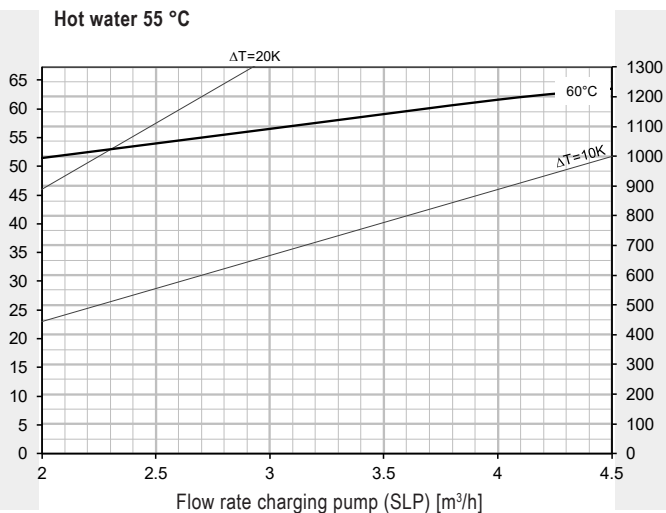
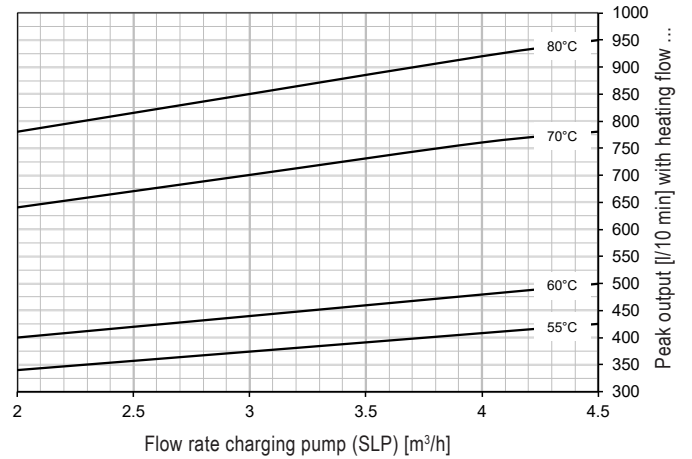

Pressure drop heating coil - delivery head charging pump

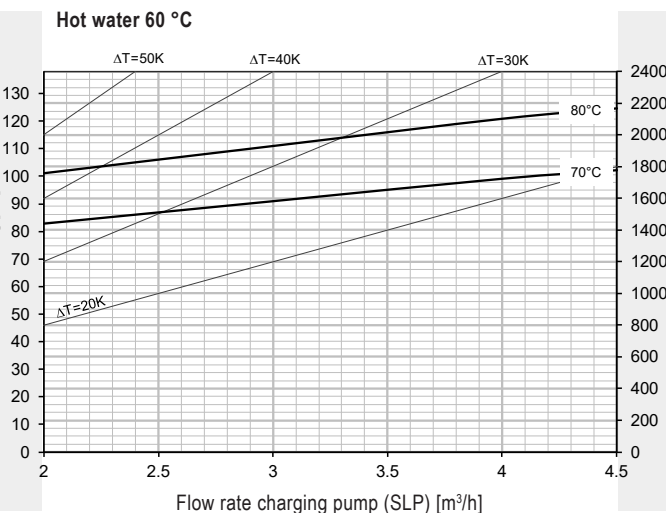
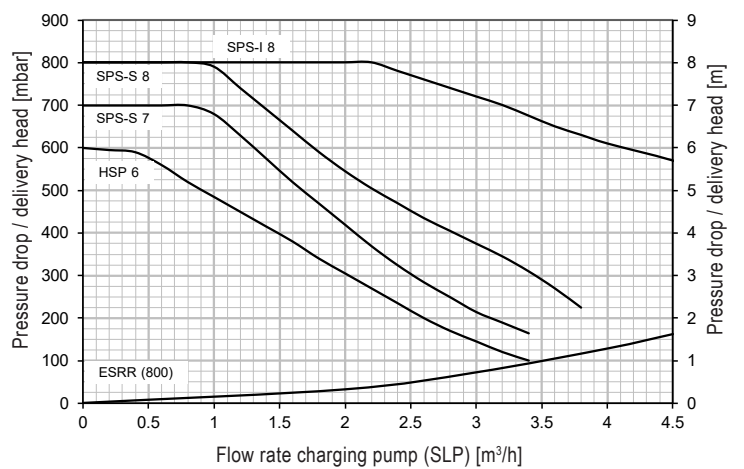

* Calorifier heated to 60 °C

MultiVal ESRR (1000)

Hot water output
Continuous output

Reading example
see engineering

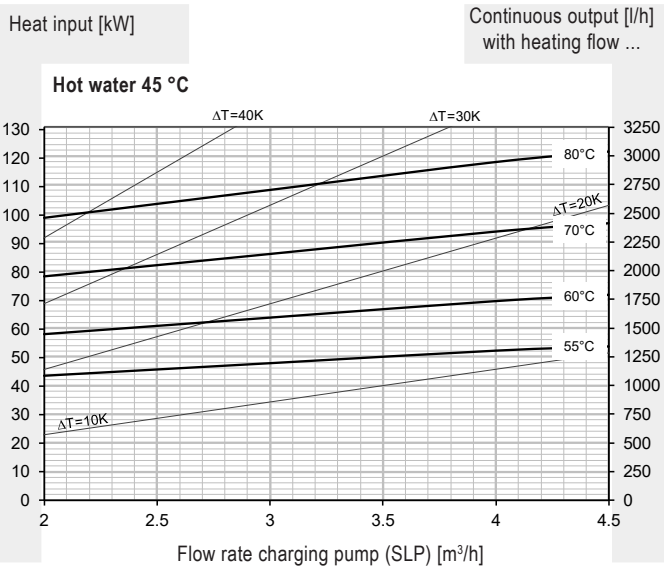

10 min peak output - hot water 45 °C *

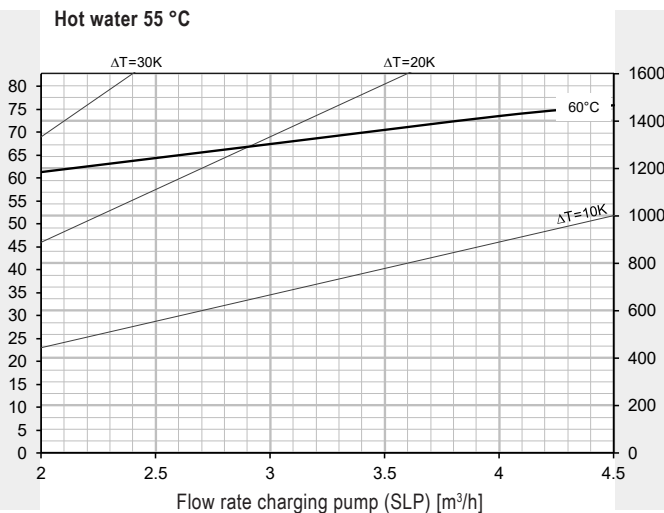
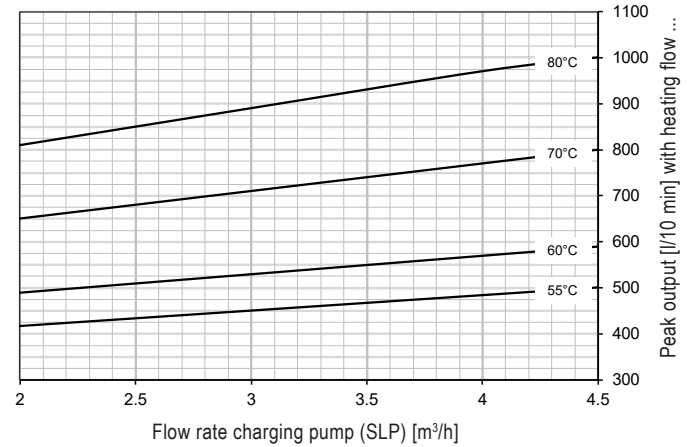

Pressure drop heating coil - delivery head charging pump

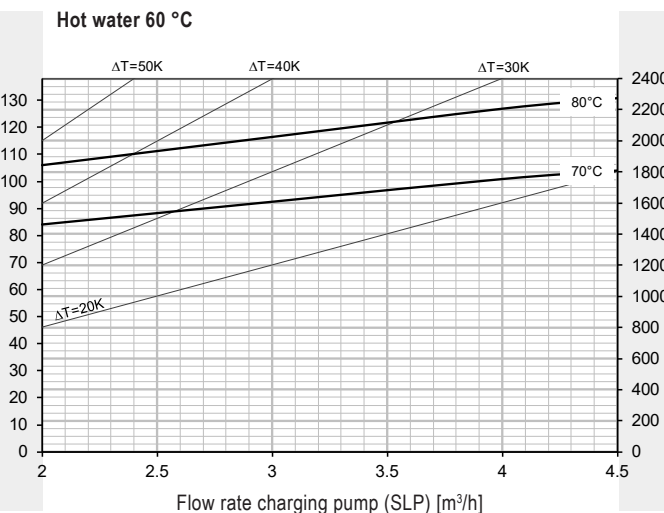
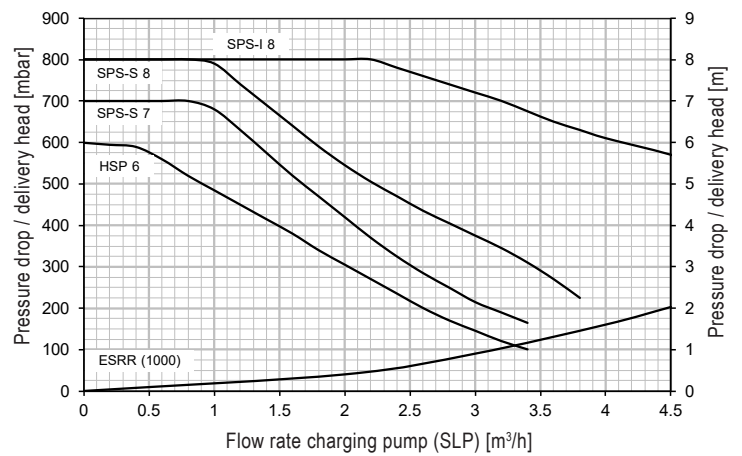

* Calorifier heated to 60 °C

MultiVal ESRR (500)
(Dimensions in mm)

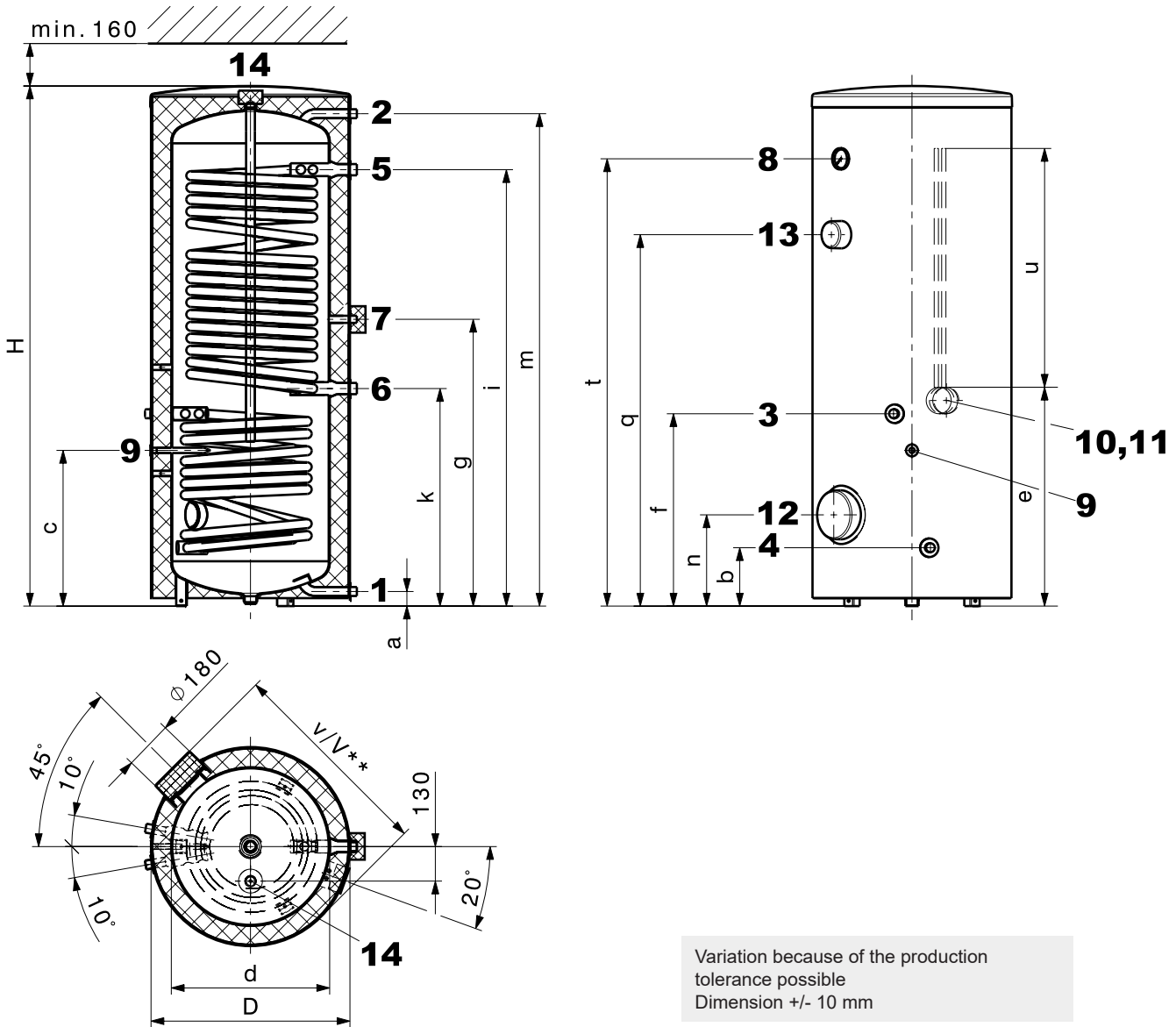

Variation because of the production tolerance possible
Dimension +/- 10 mm

- | | | | |
|---|-------------|---|-------------|
| 1 Cold water | G 1" (ET) | 10 2 sensor channels inner Ø 11 mm | |
| 2 Domestic hot water | G 1" (ET) | 11 Removable cap (Ø 100 mm)
for positioning the sensor in the sensor channel | |
| 3 Solar circuit flow | G 1" (ET) | 12 Hand-hole flange (flange-mounted electric heating element)
Ø 180/120 mm, pitch circle Ø 150 mm, 8 x M10 | |
| 4 Solar circuit return | G 1" (ET) | 13 Connection for screw-in electric heating element (cap Ø 100 mm) | Rp 1½" (IT) |
| 5 Flow supplemental heating | G 1¼" (ET) | 14 Anode sleeve | Rp 1¼" (IT) |
| 6 Return supplemental heating | G 1¼" (ET) | | |
| 7 Circulation (removable insulated cap Ø 100 mm) | G ¾" (ET) | | |
| 8 Thermometer | | | |
| 9 Connection for sensor/thermostat, inner Ø 16 mm | Rp 1½" (ET) | | |

MultiVal ESRR type	D	d	H	a	b	c	e	f	g	i	k	m	n	q	t	u	v	v**	Tilting dimension
(500)	750	597	1951	55	220	587	820	725	1081	1645	820	1856	344	1400	1686	900	791	831	2029

** when using a flange-mounted electric heating element

MultiVal ESRR (800,1000)
(Dimensions in mm)

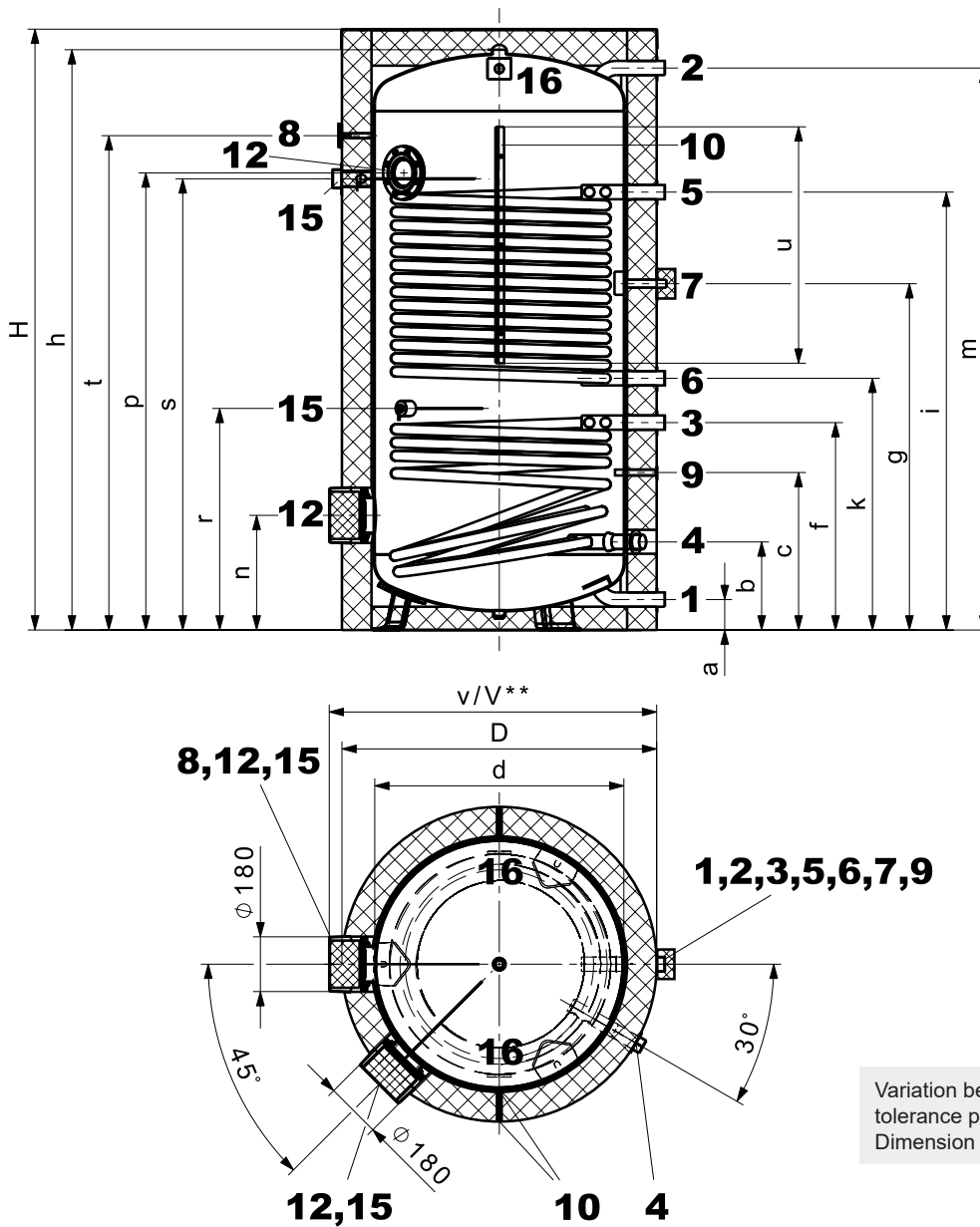

Variation because of the production tolerance possible
Dimension +/- 10 mm

- | | | |
|-------------------------------|------------------------------------|---|
| 1 Cold water | G 1½" (ET) | 8 Thermometer |
| 2 Domestic hot water | G 1½" (ET) | 9 Connection for sensor/thermostat, inner Ø 16 mm |
| 3 Solar circuit flow | G 1½" (ET) | 10 Sensor terminal strip (zip fastener) |
| 4 Solar circuit return | G 1½" (ET) | 12 Hand-hole flange (flange-mounted electric heating element) |
| | (turned through 30° in section) | Ø 180/120 mm, pitch circle Ø 150 mm, 8 x M10 |
| 5 Flow supplemental heating | G 1½" (ET) | 15 Correx® impressed current anode sleeve Rp ¾" (IT) |
| 6 Return supplemental heating | G 1½" (ET) | 16 Transport strap |
| 7 Circulation | G ¾" (ET) | |
| | (removable insulated cap Ø 100 mm) | |

MultiVal ESRR type	D	d	H	h	a	b	c	f	g	i	k	m	n	p	r	s	t	u	v	v**	Tilting dimension
(800)	950	750	2033	1936	104	290	527	650	1120	1430	800	1890	382	1540	750	1455	1647	800	975	1020	1962
(1000)	1050	850	2063	1963	103	298	533	702	1172	1482	852	1902	388	1547	750	1527	1673	800	1075	1120	1991

** when using a flange-mounted electric heating element