

VarioVal FLS (800,1000)
Stratified storage tank
(suitable for heat pumps)

Stratified storage tank

- For single family homes with approx. 4-6 persons
- Heating with solar, low-temperature heat generator (heat pumps) or for high-temperature heat generators
- Annual solar coverage rate depends on heat demand, collector field size, collector field storage ratio and location
- Stratified storage tank made of steel, primed on the outside, for heating support
- Water heating via fresh water module (option)
- With built-in plain tube heat exchanger for connection to solar collectors (800) up to 10 m² collector surface (1000) up to 15 m² collector surface
- Layer installations:
 - Stratification pipe (pipe in pipe)
 - Horizontal baffle plates
 - Vertical baffle plates
 - Guide tubes (bent upwards/downwards) for fresh water module connections
 - Heating flow/return guide tubes (also with return in layer channel)
 - Separating plate in the central area for separation of the temperature zone
- Sensor terminal blocks
- Thermometer (with capillary)
- Thermal insulation
 - Made of polyester fibre fleece 140 mm
 - Outer plastic jacket with patented aluminium sealing bracket, red
 - Insulated cover flap (can be knocked out) for heat exchanger connections

Delivery

Calorifier and thermal insulation completely installed (can be removed for installation)

Design on request

- Heating module HMV20-3BM/SPS-S 8 with thermal insulation box
- Can be expanded with
 - Heating armature group HAV20-3BM-R/SPS-S 8
 - Solar armature group SAV20/SPS-S 7
- Fresh water module
 - TransTherm® aqua FT/FTC: For direct storage tank mounting with supplied fixing bolts (not pre-assembled) and connection set
 - TransTherm® aqua F: wall installation (pipework on site)
- Circulation lance
- Screw-in electric heating element



VarioVal FLS

VarioVal FLS incl. TransTherm® aqua FT/FTC

Model range

VarioVal FLS type	Solar heat exchanger	
	m ²	dm ³
(800)	2	13.4
(1000)	3	18.9

Notice

SPF certificate stratification efficiency
SPF-18-009-SE

VarioVal FLS (800,1000) - selection table

	Hydraulic components + necessary TopTronic® E modules						Additional accessories			
	1st mixer circuit	2nd mixer circuit	Solar armature group	Return switching	Buffer management	Fresh water module	Screw-in electric heating element	Electrical box	Circulation heat exchanger lance	
	•	opt.	opt.	•	•	•	•	•	opt.	
Consisting of:										
	Heating module HMV20-3BM SPS-S 8	HA group HAV20-3BM-R SPS-S 8	TopTronic® E module expansion heating circuit	Solar group SAV20FR SPS-S 7 PM2	TopTronic® E solar module	Stratified charging set SLS32-3-H RL	TopTronic® E buffer module	TransTherm® aqua F TransTherm® aqua FT TransTherm® aqua FTC		
Heat generator										
Air/water heat pumps:										
UltraSource® B comfort C (8,11)	•	•	•	•	•	•		•	opt. ²⁾	opt.
Belaria® pro comfort (8-15)	•	•	•	•	•	•		•	opt. ²⁾	opt.
Belaria® comfort ICM (8,13)	•	•	•	•	•	•		•	opt. ²⁾	opt.
Brine heat pumps:										
UltraSource® T comfort (8,13)	•	•	•	•	•	•		•	opt.	opt. ²⁾
Thermalia® comfort (8-13)	•	•	•	•	•	•		•	opt.	opt. ²⁾
Thermalia® comfort H (7,10)	•	•	•	•	•	•		•	opt.	opt. ²⁾
TopGas® classic (12-30)	•	•	•	•	•	3)	•	•	opt.	opt. ²⁾
UltraGas® (15-35)	•	•	•	•	•		•	•	opt.	opt. ²⁾
UltraOil® (16-35)	•	•	•	•	•		•	•	opt.	opt. ²⁾
BioLyt (13-25)	•	•	•	•	•		•	•	opt.	opt. ¹⁾

¹⁾ A module expansion or a controller module can be installed in the heat generator.

²⁾ Two TopTronic® E controller modules can be mounted in the heat generator or in the wall casing. If the storage tank is fully equipped, a separate electrical box must be ordered for an additional module.

³⁾ Return switching to be installed by the client.

Stratified storage tank



VarioVal FLS (800,1000)

Stratified storage tank made of steel, primed on the outside, for heating support. Water heating optionally via fresh water module. With built-in plain tube heat exchanger for connection to solar collectors. Thermal insulation made of polyester fibre 140 mm and external plastic coating, colour red. Suitable for heat pumps up to 20 kW (up to 2500 l/h).

VarioVal FLS type	Total volume dm ³	Solar heat exchanger	
		m ²	dm ³
(800)	796	2	13.4
(1000)	892	3	18.9

Part No.

6046 238
6046 239

Electric heating elements

see chapter "Electric heating elements"

Accessories



Heating module HMV20-3BM
with pressure distributor for 2 mixer circuits, incl. 1 heating armature group with 3-way motor mixer and pump SPS-S 8 and thermal insulation box

Part No.

6046 091

Notice

In combination with heat pumps, always use the stratified charging set SLS32-3-H RL.



Heating armature group HAV20-3BM-R
to extend the HMV20-3BM for a second mixer circuit
Pump SPS-S 8

6046 092

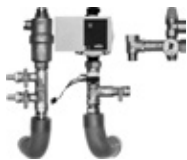

Solar armature group SAV20FR
with PWM interface (TopTronic® E)
incl. safety group 6 bar with manometer, FlowRotor and air vent
Pump SPS-S 7 PM2

6046 093



Layer charge set SLS32-3-H RT
connection set for return switching
for direct mounting on VarioVal for heat pumps up to 17 kW
Connection set between tank and pressure distributor on heating module, layer charge set with 3-way valve incl. motor drive.

6048 003

Accessories

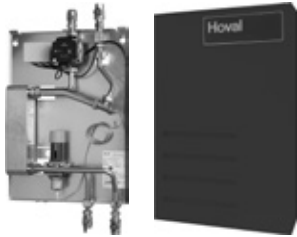

Fresh water module

TransTherm® aqua FT/FTC

Fresh water module for hygienic water heating with thermostatic control of the hot water temperature by means of quick-acting water temperature controller. Incl. red casing and connection set AS20-FW for direct installation on the VarioVal FLS.

Fresh water module TransTherm® aqua	Output kW
FT (65)	65
FTC (57)	57

Part No.

6046 240
6046 241

Accessories for TransTherm® aqua FT/FTC



Circulation heat exchanger lance R 1"

is screwed into the buffer storage tank and integrated into the circulation line.

Material: Copper, tinned inside
Transmission power approx. 1 kW at 60 °C
Hot water temperature in the buffer storage tank without mixing through the storage tank temperature.
Circulation connections R ½"
Installation length 660 mm

2038 434

Accessories for TransTherm® aqua F



TransTherm® aqua F

Fully assembled station with plate heat exchanger for the provision of domestic hot water using the continuous flow principle and built-in Hoval TopTronic® E control.

The required buffer storage tank is not supplied.

Fresh water module TransTherm® aqua F	Output kW
(6-10)	50
(6-16)	90

Part No.

8006 387
8006 388

Version with copper-free heat exchanger

Fresh water module TransTherm® aqua F	Output kW
(6-10)	50
(6-16)	90

8006 521
8006 522



Return switching valve set DN 20
for TransTherm® aqua F (50–90 kW)
Set consisting of temperature sensor, switching valve, drive, seals and screw fittings.

7010 832



Test valve DN 8 G ¼"
for TransTherm® aqua L, F, FS
Test valve suitable for flame treatment for hygienic-microbiologic tests.

2049 861



Sludge separator with magnet
Type: MB3 DN 25 Rp 1"
With variable connection for vertical or horizontal pipelines
Removal of ferromagnetic and non-magnetic dirt and sludge particles from heating or cooling circuits with the medium water or water/glycol (50/50 %)
Brass casing
Sludge separation up to a particle size of 5 µm
With unscrewable casing bottom part for cleaning and inspection work complete with sludge removal tap

2062 165

Nominal diameter: DN 25
Pipe connection: Rp 1" internal thread
Installation length: 90 mm
Max. operating pressure: 6 bar
Max. flow temperature: 110 °C
Max. throughput: 2.0 m³/h
Max. flow speed: 1.0 m/s
Max. pressure drop: 3.8 kPa
Contents: 0.36 l
Weight: 2.3 kg

Accessories



Sludge separator with magnet

Type: MBL DN 32 Rp 1¼"
 With variable connection for vertical or horizontal pipelines
 Performance-enhancing magnetic assistance from removable, external magnet.
 Fast and continuous removal of ferromagnetic and non-magnetic dirt and sludge particles from heating or cooling circuits with the medium water or water/glycol (50/50 %)
 Brass casing
 Sludge separation up to a particle size of 5 micrometres - separation and sludge removal without interrupting operation by the spiral pipe insert
 With unscrewable casing bottom part for cleaning and inspection work complete with sludge removal tap.

Nominal diameter: DN 32
 Pipe connection: Rp 1¼"
 (internal thread)
 Installation length: 128 mm
 Max. operating pressure: 10 bar
 Max. flow temperature: 110 °C
 Max. throughput: 3.6 m³/h
 Max. flow speed: 1.0 m/s
 Max. pressure drop: 2.2 kPa
 Contents: 0.75 l
 Weight: 3.6 kg
 Type: MBL DN 32 IT

Additional sludge separators
 see "Various system components"

Notice
 Information about engineering, space requirement, dimensioning table, dimensions, see "Hoval TransTherm® aqua F"



TopTronic® E control module black with 4.3" colour touchscreen

For operation of all controller modules connected to the bus system (basic, solar, buffer modules etc.)
 Connection to the Hoval bus system via RJ45 plug connection or via plug terminals (max. 0.75 mm²), flat design with flexible installation option
 Installation:
 - in control panel of the heat generator
 - in the Hoval wall casing
 - in the control panel front, black high-gloss cover, customer-specific configurable start screen,
 Display of current weather or weather forecast (only possible in combination with HovalConnect)

Consisting of:
 - TopTronic® E control module black
 - Clamping device set control module
 - RJ45-RAST 5 CAN cable, L = 500

Part No.

2062 166

6043 844

TopTronic® E controller modules

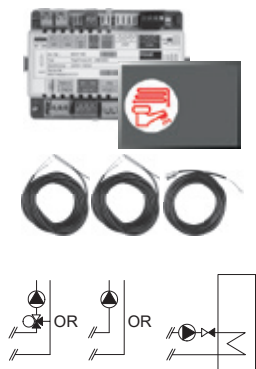

TopTronic® E heating circuit/hot water module TTE-HK/WW

Controller module for controlling consumers with integrated control functions for:

- 1 heating/cooling circuit w/o mixer or
- 1 heating/cooling circuit with mixer or
- 1 hot water charging circuit
- various additional functions

Consisting of:

- Fitting accessories
- 2 x immersion sensor TF/2P/5/6T, L = 5 m
- 1 contact sensor ALF/2P/4/T, L = 4 m
- Basic plug set for controller module



TopTronic® E solar module TTE-SOL

The controller module is suitable for use as temperature differential control, control of thermal solar plants, for heating process water and/or heating support.

Controller module with integrated control functions for

- solar circuit
- collector cascade
- storage tank cascade with up to 4 consumers
- consumer loading, with type selection
- temperature differential control
- loading and unloading function for additional/reserve buffer tank
- Integrated solar yield calculation

Consisting of:

- Fitting accessories
- 1 immersion sensor TF/2P/5/6T, L = 5 m
- 1 collector sensor TF/1.1P/2.5S/5.5T L = 2.5 m
- Basic plug set for controller module

Notice

In a standalone application, the control module for operating the solar module and a wall casing must be ordered separately!

Notice

Depending on the complexity, module expansions are required for using the listed functions (max. 2 module expansion can be connected)!

Notice

The supplementary plug set may have to be ordered to implement functions differing from the standard!

Part No.

6034 571

6037 058

TopTronic® E controller modules

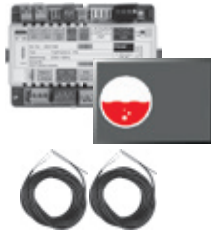

TopTronic® E buffer module TTE-PS

Controller module with integrated control functions for:

- heating buffer management or
- cooling buffer management
- var. additional functions

Consisting of:

- Fitting accessories
- 2 immersion sensors TF/2P/5/6T L = 5 m
- Basic plug set for controller module

Notice

If the controller module is used without Hoval heat generator then a TopTronic® E control module must be ordered separately!

Notice

Depending on the complexity, module expansions are required for using the listed functions (max. 2 module expansion can be connected)!

Notice

The supplementary plug set may have to be ordered to implement functions differing from the standard!



TopTronic® E module expansion Universal TTE-FE UNI

Expansion to the inputs and outputs of a controller module (basic module heat generator, heating circuit/domestic hot water module, solar module, buffer module) for implementing various functions

Consisting of:

- Fitting accessories
- Plug set FE module

Notice

Refer to the Hoval System Technology to find which functions and hydraulic arrangements can be implemented.

Part No.

6037 057

6034 575

Accessories for TopTronic® E



Supplementary plug set
for controller modules and module expansion
TTE-FE HK

6034 503



TopTronic® E room control modules
TTE-RBM TopTronic® E room control modules
easy white
comfort white
comfort black

6037 071
6037 069
6037 070



Enhanced language package TopTronic® E
one SD card required per control module
Consisting of the following languages:
HU, CS, SL, RO, PL, TR, ES, HR,
SR, JA, DA

6039 253



HovalConnect
HovalConnect LAN
HovalConnect WLAN
HovalConnect Modbus
HovalConnect KNX

6049 496
6049 498
6049 501
6049 593

TopTronic® E interface modules
GLT module 0-10 V

6034 578



TopTronic® E sensors
AF/2P/K Outdoor sensor
H x W x D = 80 x 50 x 28 mm
TF/2P/5/6T Immersion sensor, L = 5.0 m
ALF/2P/4/T Contact sensor, L = 4.0 m
TF/1.1P/2.5S/6T Collector sensor, L = 2.5 m

2055 889
2055 888
2056 775
2056 776



Bivalent switch
for various release or switching functions
Bivalent switch 1-piece
Bivalent switch 2-piece

2056 858
2061 826

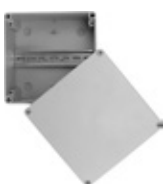

System housing
System housing 182 mm
System housing 254 mm

6038 551
6038 552



TopTronic® E wall casing
WG-190 Wall casing small
WG-360 Wall casing medium
WG-360 BM Wall casing medium with
control module cut-out
WG-360-3 BM Wall casing compact with
control module cut-out
WG-510 Wall casing large
WG-510 BM Wall casing large with
control module cut-out

6052 983
6052 984
6052 985
6052 988
6052 986
6052 987

Further information
see "Controls"

Services



Commissioning

Commissioning by works service or Hoval trained authorised serviceman/company is condition for warranty.

For commissioning and other services please contact your Hoval sales office.

Part No.

VarioVal FLS (800,1000)

Type		(800)	(1000)
Storage tank			
• Total volume	dm ³	796	892
• Usable volume	dm ³	777	872
• Operating pressure/test pressure	bar	3/4.5	3/4.5
• Max. operating temperature	°C	95	95
• Transport weight	kg	228	233
• Dimensions		See Dimensions	
Solar coil (permanently installed)			
• Heating surface	m ²	2	3
• Contents	dm ³	13.4	18.9
• Operating pressure/test pressure	bar	10/15	10/15
• Max. operating temperature	°C	110	110
• Flow resistance ¹⁾ water/glycol 50 % (z-value)		19	25
• Number of collectors (max. - gross at 2.5 m ²)	pieces	4	6
• For flat collectors ²⁾ up to approx.	m ²	10	15
Thermal insulation			
• Insulation type		PE fibre fleece	PE fibre fleece
• Insulation thickness	mm	140	140
• Fire protection class		B2	B2
• Thermal conductance λ	W/mK	0.038	0.038
• U value	W/(m ² K)	0.27	0.27
• Heat loss at 65 °C	W	91	100
• Energy efficiency class		B	B

¹⁾ Flow resistance of heating coil in mbar = flow rate (m³/h)² x z (1 mbar = 0.1 kPa)

²⁾ Collector surface area, with regard to heat exchanger area only

Performance data

TransTherm® aqua FT/FTC

Hoval TransTherm® aqua FT (65)

Hot water temperature 45 °C: tapping capacity - output - pressure drops

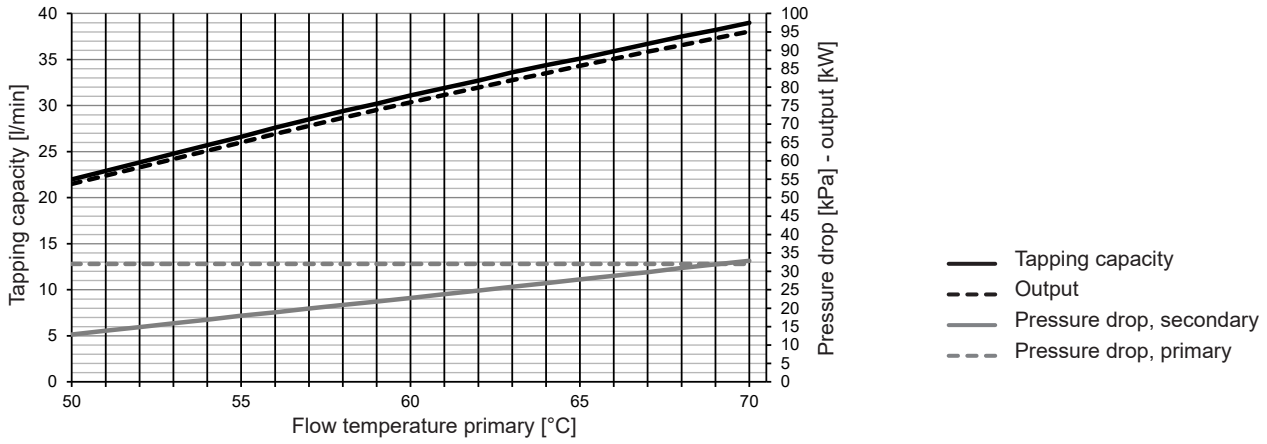

Hoval TransTherm® aqua FTC (57)

Hot water temperature 45 °C: tapping capacity - output - pressure drops

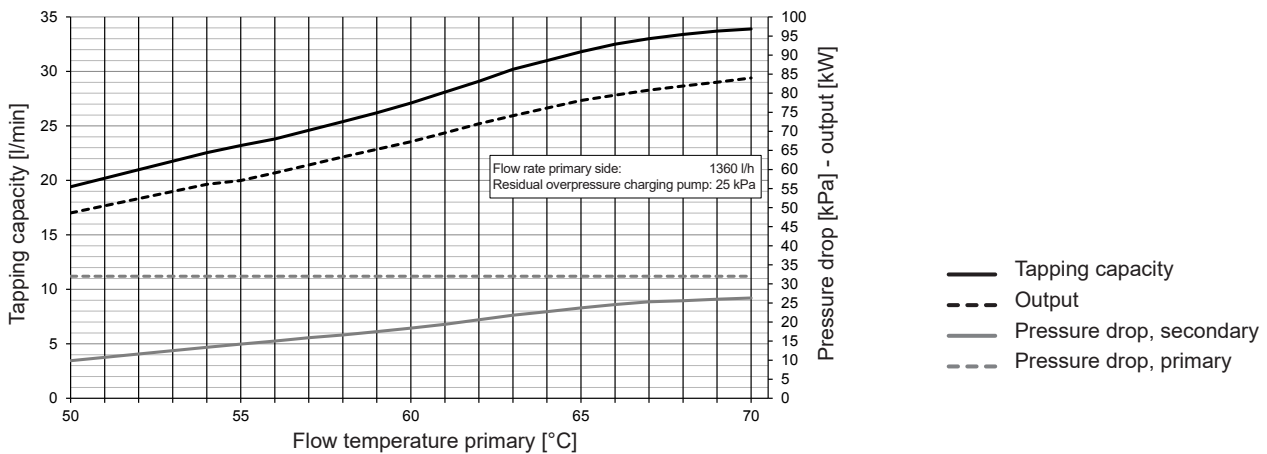

Performance data

TransTherm® aqua F (6-10 up to 6-16)

		Heating water temperature flow							
		55 °C (6-...)		60 °C (6-...)		65 °C (6-...)		70 °C (6-...)	
DHW secondary	TransTherm® aqua F	(10)	(16)	(10)	(16)	(10)	(16)	(10)	(16)
60/5 °C	T return primary °C	-	-	-	-	30	30	30	30
	Ṁ primary m³/h	-	-	-	-	1.08	1.88	1.32	2.09
	Q max. kW	-	-	-	-	43	75	60	95
	Ṁ secondary m³/h	-	-	-	-	0.67	1.17	0.94	1.48
60/10 °C	T return primary °C	-	-	-	-	30	30	30	30
	Ṁ primary m³/h	-	-	-	-	0.8	1.5	1.08	1.94
	Q max. kW	-	-	-	-	32	60	50	90
	Ṁ secondary m³/h	-	-	-	-	0.55	1.03	0.86	1.54
60/15 °C	T return primary °C	-	-	-	-	30	30	30	30
	Ṁ primary m³/h	-	-	-	-	0.55	1.05	0.97	1.8
	Q max. kW	-	-	-	-	22	42	44	82
	Ṁ secondary m³/h	-	-	-	-	0.42	0.8	0.84	1.57
60/20 °C	T return primary °C	-	-	-	-	30	30	30	30
	Ṁ primary m³/h	-	-	-	-	0.3	0.6	0.62	1.14
	Q max. kW	-	-	-	-	12	24	28	52
	Ṁ secondary m³/h	-	-	-	-	0.26	0.52	0.6	1.12
55/5 °C	T return primary °C	-	-	30	30	30	30	30	30
	Ṁ primary m³/h	-	-	1.25	2.04	0.8	1.5	1.08	2.09
	Q max. kW	-	-	43	70	32	60	50	95
	Ṁ secondary m³/h	-	-	0.74	1.2	0.55	1.03	0.86	1.63
55/10 °C	T return primary °C	-	-	30	30	30	30	30	30
	Ṁ primary m³/h	-	-	1.11	2.04	1.3	2.06	1.08	1.87
	Q max. kW	-	-	38	70	52	82	49	85
	Ṁ secondary m³/h	-	-	0.73	1.34	0.99	1.57	0.94	1.62
55/15 °C	T return primary °C	-	-	30	30	30	30	30	30
	Ṁ primary m³/h	-	-	0.76	1.46	0.97	1.65	1.1	1.88
	Q max. kW	-	-	26	50	44	75	44	75
	Ṁ secondary m³/h	-	-	0.56	1.08	0.95	1.61	0.94	1.62
55/20 °C	T return primary °C	-	-	30	30	30	30	30	30
	Ṁ primary m³/h	-	-	0.47	0.9	0.95	1.68	0.84	1.47
	Q max. kW	-	-	16	31	38	67	38	67
	Ṁ secondary m³/h	-	-	0.39	0.76	0.94	1.65	0.94	1.65
50/5 °C	T return primary °C	30	30	30	30	30	30	30	30
	Ṁ primary m³/h	1.29	2.03	1.28	2.04	1.25	2.06	1.08	1.87
	Q max. kW	37	58	44	70	50	82	49	85
	Ṁ secondary m³/h	0.71	1.11	0.84	1.34	0.95	1.57	0.94	1.62
50/10 °C	T return primary °C	30	30	30	30	30	30	30	30
	Ṁ primary m³/h	1.29	2.03	1.28	2.04	1.1	1.88	0.97	1.65
	Q max. kW	38	58	44	70	44	75	44	75
	Ṁ secondary m³/h	0.82	1.25	0.95	1.51	0.95	1.61	0.95	1.61
50/15 °C	T return primary °C	30	30	30	30	30	30	30	30
	Ṁ primary m³/h	1.29	2.03	1.11	1.95	0.95	1.68	0.84	1.47
	Q max. kW	37	58	38	67	38	67	38	67
	Ṁ secondary m³/h	0.91	1.43	0.94	1.65	0.94	1.65	0.94	1.65
50/20 °C	T return primary °C	30	30	30	30	30	30	30	30
	Ṁ primary m³/h	1.15	2.03	0.96	1.69	0.83	1.45	0.73	1.28
	Q max. kW	33	58	33	58	33	58	33	58
	Ṁ secondary m³/h	0.95	1.67	0.95	1.67	0.95	1.67	0.95	1.67
45/5 °C	T return primary °C	19	18	17	16	16	15	15	13
	Ṁ primary m³/h	0.86	1.91	0.86	1.92	0.87	1.83	0.84	1.62
	Q max. kW	35	80	42	95	48	104	52	104
	Ṁ secondary m³/h	0.76	1.73	0.90	2.05	1.04	2.24	1.13	2.24
45/10 °C	T return primary °C	21	21	20	19	19	17	17	16
	Ṁ primary m³/h	0.86	1.91	0.86	1.92	0.87	1.69	0.77	1.49
	Q max. kW	33	74	39	89	45	91	46	91
	Ṁ secondary m³/h	0.81	1.84	0.97	2.20	1.13	2.25	1.13	2.24
45/15 °C	T return primary °C	24	23	23	22	21	20	20	19
	Ṁ primary m³/h	0.86	1.91	0.87	1.8	0.8	1.55	0.71	1.36
	Q max. kW	30	69	37	78	39	78	40	78
	Ṁ secondary m³/h	0.88	1.99	1.07	2.26	1.14	2.27	1.16	2.26
45/20 °C	T return primary °C	27	26	25	25	24	23	23	23
	Ṁ primary m³/h	0.86	1.92	0.85	1.63	0.72	1.4	0.63	1.22
	Q max. kW	27	63	33	65	33	66	33	65
	Ṁ secondary m³/h	0.96	2.18	1.16	2.27	1.16	2.29	1.15	2.27

T return primary °C Primary return temperature
Ṁ primary m³/h Primary flow rate
 Q max. kW Output
Ṁ secondary m³/h Secondary flow rate

The specified technical data relates to the full load of the module in each case.

Residual overpressure heating module HMV20-3BM

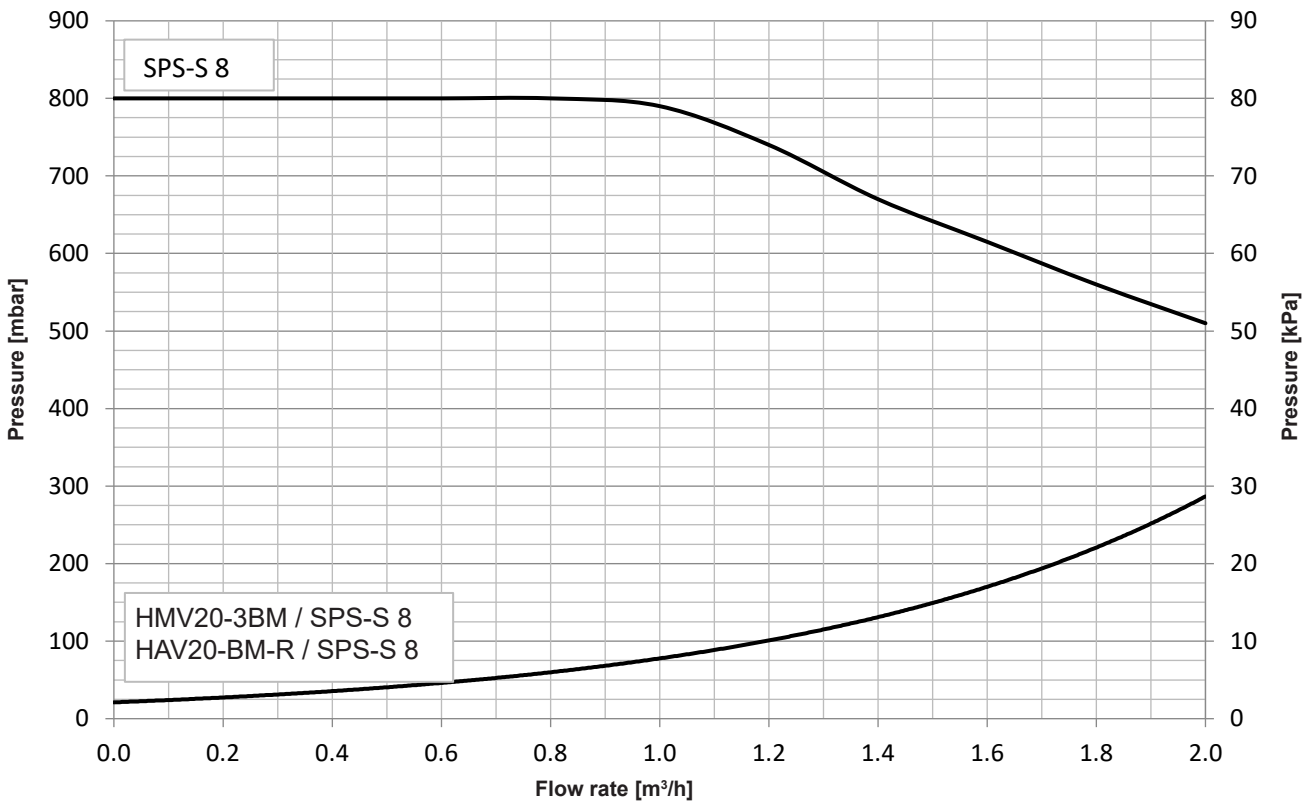

Residual overpressures solar group SAV20

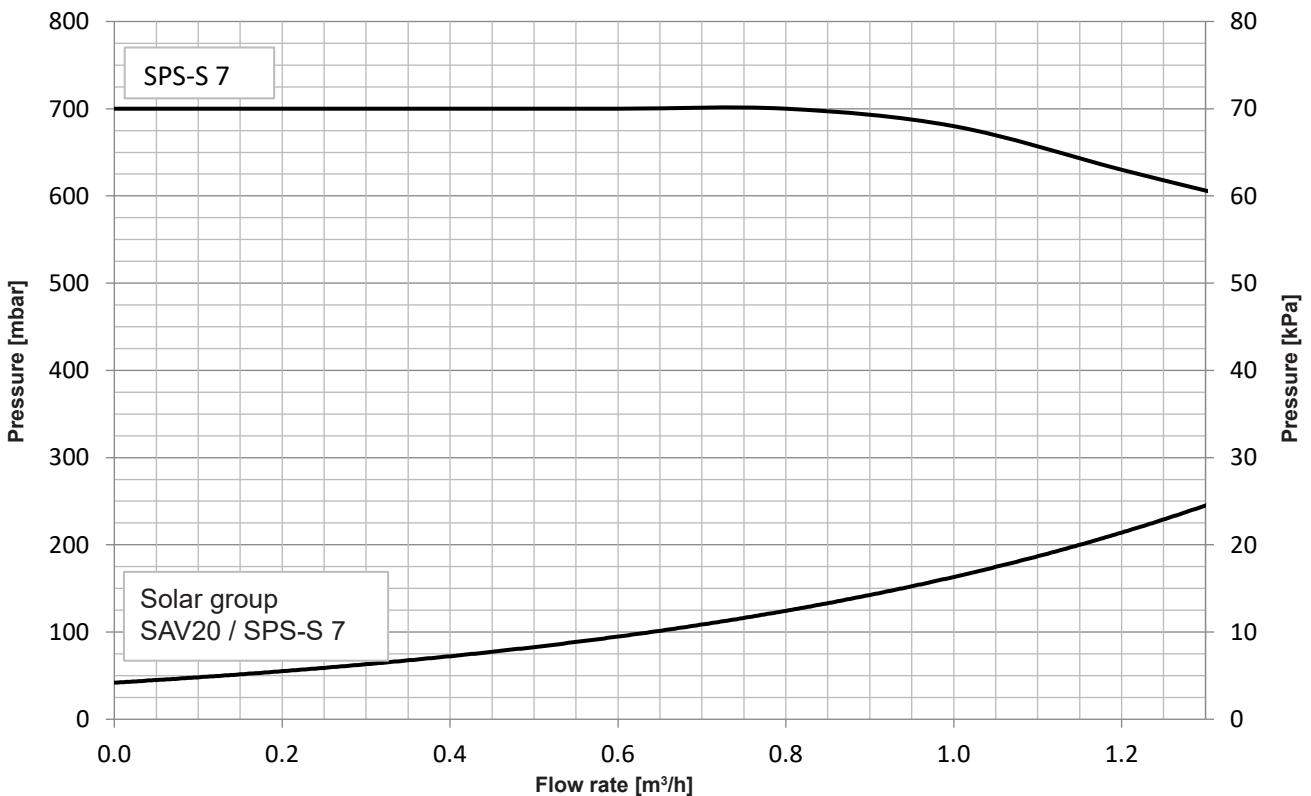

VarioVal FLS (800-1000)
(Dimensions in mm)

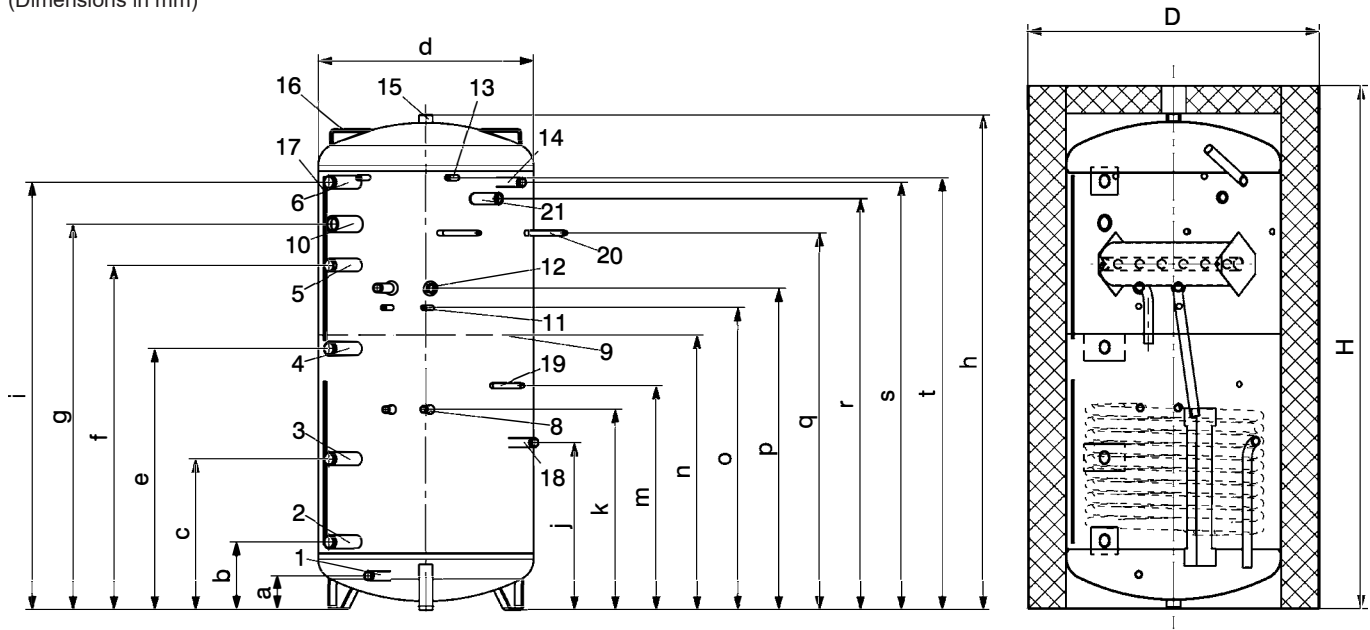

Deviations possible as a result of manufacturing tolerances.
Dimensions +/- 10 mm

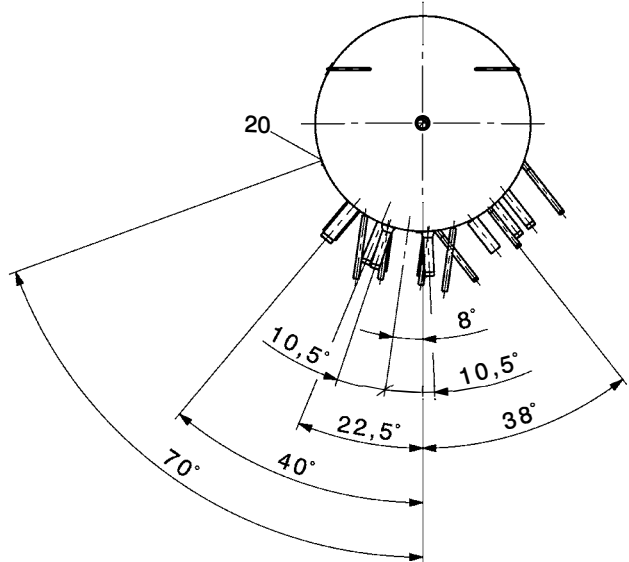

- 1 Drain G 1" (ext. thread)
- 2 Heat generator connection bottom (vertical baffle plate) G 1½" (ext. thread)
- 3 Heat generator connection 2 - bottom (inflow restrictor) G 1½" (ext. thread)
- 4 Heat generator connection middle (inflow restrictor) G 1½" (ext. thread)
- 5 Heat generator connection 2 - top (stratification pipe) G 1½" (ext. thread)
- 6 Heat generator connection top (vertical baffle plate) G 1½" (ext. thread)
- 8 Flow (left) and return (right) solar circuit G ¾" (ext. thread)
- 9 Separating plate
- 10 Connection for screw-in electric heating element Rp 1½" (int. thread)
- 11 Fixing bolts bottom left and right for solar group M10 (int. thread)
- 12 Flow (left) and return (right) heating G 1" (ext. thread)
- 13 Fixing bolts top left and right for heating group M10 (int. thread)
- 14 Connection for fresh water station warm flow G 1" (ext. thread)
- 15 Possible air vent Rp 1¼" (int. thread)
- 16 Carry handle (2 x)
- 17 Sensor terminal strip (type (800) 2 x, type (1000) 3 x)
- 18 Connection for fresh water station warm cold return G 1" (ext. thread)
- 19 Bolt at bottom for fresh water station
- 20 Fixing bolts top left and right for fresh water station M10 (int. thread)
- 21 Connection for circulation lance R 1" (int. thread)

VarioVal FLS type	D	d	H	h	a	b	c	e	f	g	i	j	k	m	n	o	p	q	r	s	t	Tilting dimension
(800)	1070	790	1919	1816	125	249	554	959	1264	1415	1569	614	736	823	1009	1109	1180	1383	1509	1569	1586	1828
(1000)	1070	790	2119	2016	125	249	554	959	1264	1415	1569	814	870	1023	1009	1243	1314	1583	1709	1769	1720	2030

Space requirements

Installation example - VarioVal FLS

- Heating module HMV20-3B
- HA group HAV20-3BM-R
- Solar group SAV20
- DH module TransTherm® aqua FT (65)

Notices on operation and accessibility

The operating side must be easily accessible. Preferably place heat generator to the left of the storage tank.

Accessibility, left according to heat generator (a):

- Installation and removal of the screw-in electric heating element
 - Thermal insulation can be opened to position the sensors in the terminal strips
 - Wall clearance, right (c): Installation of the diaphragm pressure expansion tank
 - Removal and installation of the DH module or the hood
 - Hot water (domestic water) flow and return
- Distance from the ceiling, top:
- Possibly for safety set

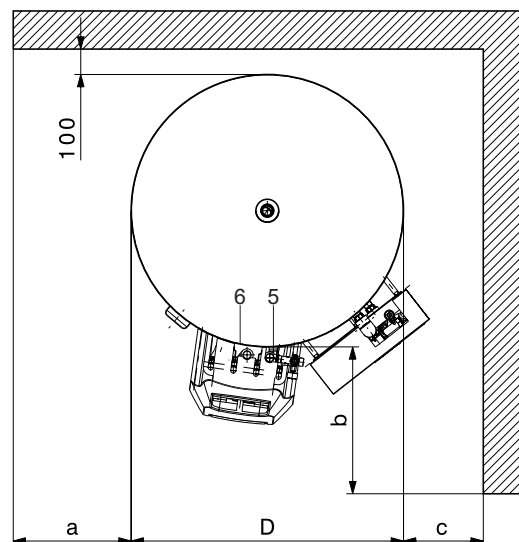
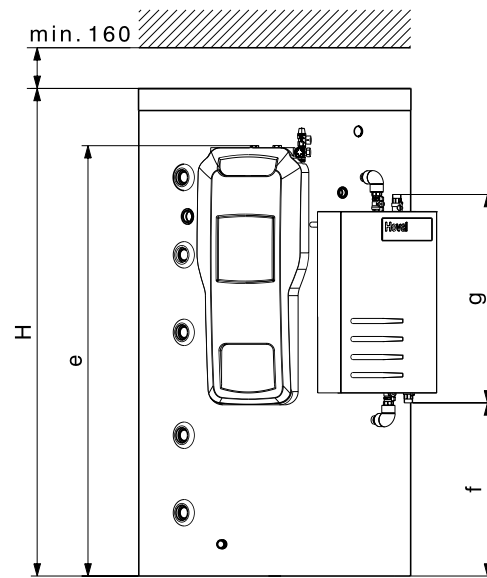

VarioVal FLS	a	b	c	D	e	f	g	H
(800)	≥ 650	≥ 1000	≥ 500	1070	1694	682	820	1919
(1000)	≥ 650	≥ 1000	≥ 500	1070	1828	882	820	2119

Representation without thermal insulating hood and DH module hood

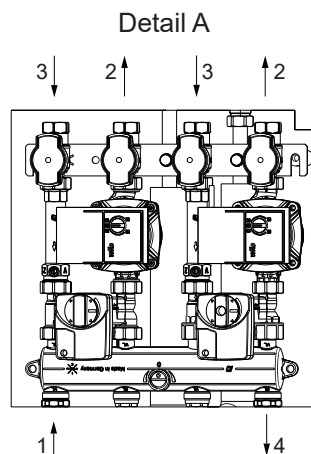
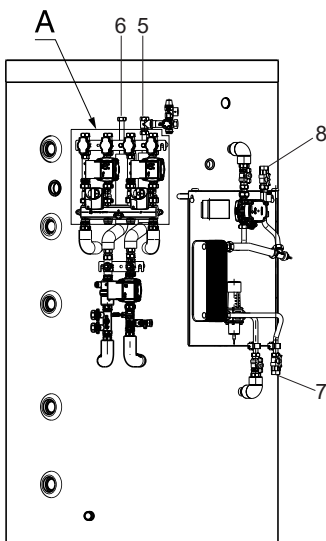

- 1 Heating flow G 1" (ET)
- 2 Flow heating circuit Rp 3/4" (IT)
- 3 Return heating circuit Rp 3/4" (IT)
- 4 Heating return G 1" (ET)
- 5 Solar circuit return G 3/4" (IT)
- 6 Solar circuit flow G 3/4" (IT)
- 7 Cold water Rp 3/4" (IT)
- 8 Domestic hot water Rp 3/4" (IT)